

MTR (40) Single, Dual and Triple DC-DC Converters

16 TO 40 VOLT INPUT – 20-30 WATT

FEATURES

- No cross-regulation error in triple output models
- Operating temperature -55° to +125°C
- Input voltage range 16 to 40 volts
- Transient protection 50 Vin for 50 ms
- Fully isolated, magnetic feedback
- Fixed high frequency switching
- Inhibit and synchronization function
- Indefinite short circuit and overload protection



ALSO SEE OUR IMPROVED MTR (50)
16 - 50 Vin, 80 V transient per MIL-STD-704A
datasheet

MODELS		
OUTPUT VOLTAGE (V)		
SINGLE	DUAL	TRIPLE
3.3	±5	+5 & ±12
5	±12	+5 & ±15
8.5	±15	
12		
15		
18		

DESCRIPTION

The Interpoint® MTR (40) Series™ of DC-DC converters offers up to 30 watts of power in single, dual, or triple output configurations packaged in a low profile case. The MTR (40) converters are manufactured in our fully certified and qualified MIL-PRF-38534 Class H production facility and packaged in hermetically sealed steel cases. They are ideal for use in programs requiring high reliability, small size, and high efficiency.

MTR (40) models have an input voltage range of 16 to 40 and transient protection up to 50 volts dc in for up to 50 milliseconds. They operate over the full military temperature range with up to 84% efficiency. MTR (40) converters are packaged in hermetically sealed metal cases, making them ideal for use in military, aerospace and other high reliability applications. The converters are offered with standard screening, “ES” screening, or fully compliant to “883” MIL-PRF-38534 Class H screening. See Table 13 on page 26 and Table 14 on page 27 for more information. Standard microcircuit drawings (SMD) are available. See Table 3 on page 8.

CONVERTER DESIGN

The MTR converters are constant frequency, pulse-width modulated switching regulators which use a quasi-square wave, single ended, forward converter design. Tight load regulation is maintained via wide bandwidth magnetic feedback and, on single output models, through use of remote sense. On dual output models, the positive output is independently regulated and the negative output is cross regulated through the use of tightly coupled magnetics. The MTR Series triple output DC-DC converter’s design includes individual regulators on the auxiliary outputs which provide for no cross regulation error when a minimum 300 mA load is maintained on the main (+5) output.

Indefinite short circuit protection and overload protection are provided by a constant current-limit feature. This protective system senses current in the converter’s secondary stage and limits it to approximately 125% of the maximum rated output current.

MTR converters are provided with internal filtering capacitors that help reduce the need for external components in normal operation. Use our FMCE-0328™, FMCE-0528™ or FMCE-0828™ EMI filter to meet the requirements of MIL-STD-461C CE03 and CS01 and/or MIL-STD-461D, E and F CE102 and CS101 levels of conducted emissions. Or use the FM-704A for transient suppression and to meet MIL-STD-461C CE03.

COVER MARKING

The cover marking for the MTR 40 is “MTR DC-DC CONVERTER” under the model number. See Figure 7, Figure 8 and Figure 9 on page 7.

SYNCHRONIZATION

Synchronizing the converter with the system clock allows the designer to confine switching noise to clock transitions, minimizing interference and reducing the need for filtering. In sync mode, the converter will run at any frequency between 500 kHz and 675 kHz for singles and duals and between 500 and 700 for triples. The sync control operates with a duty cycle between 40% and 60%. The sync pin must be connected to input common pin when not in use.

MTR (40) Single, Dual and Triple DC-DC Converters

16 TO 40 VOLT INPUT - 20-30 WATT

WIDE INPUT VOLTAGE RANGE

MTR converters are designed to provide full power over a full 16 to 40 volts input voltage range. Operation below 16 volts, including MIL-STD-704A emergency power conditions is possible with derated power.

DYNAMIC RESPONSE

The MTR Series feed-forward compensation system provides excellent dynamic response and audio rejection. Audio rejection is typically 40 dB for singles and duals and 50 dB for triples.

INHIBIT FUNCTION

MTR converters provide an inhibit terminal that can be used to disable internal switching, resulting in no output voltage and very low quiescent input current. The converter is inhibited when the inhibit pin is pulled below 0.8 V and enabled when its inhibit pin is left floating. An external inhibit interface should be capable of pulling the converter's inhibit pin below 0.8 V while sinking the maximum inhibit current and also allowing the inhibit pin to float high to enable the converter. A voltage should not be applied to the inhibit pin. The open circuit voltage present on the inhibit pin is 9 to 11 V.

MTR Single Output

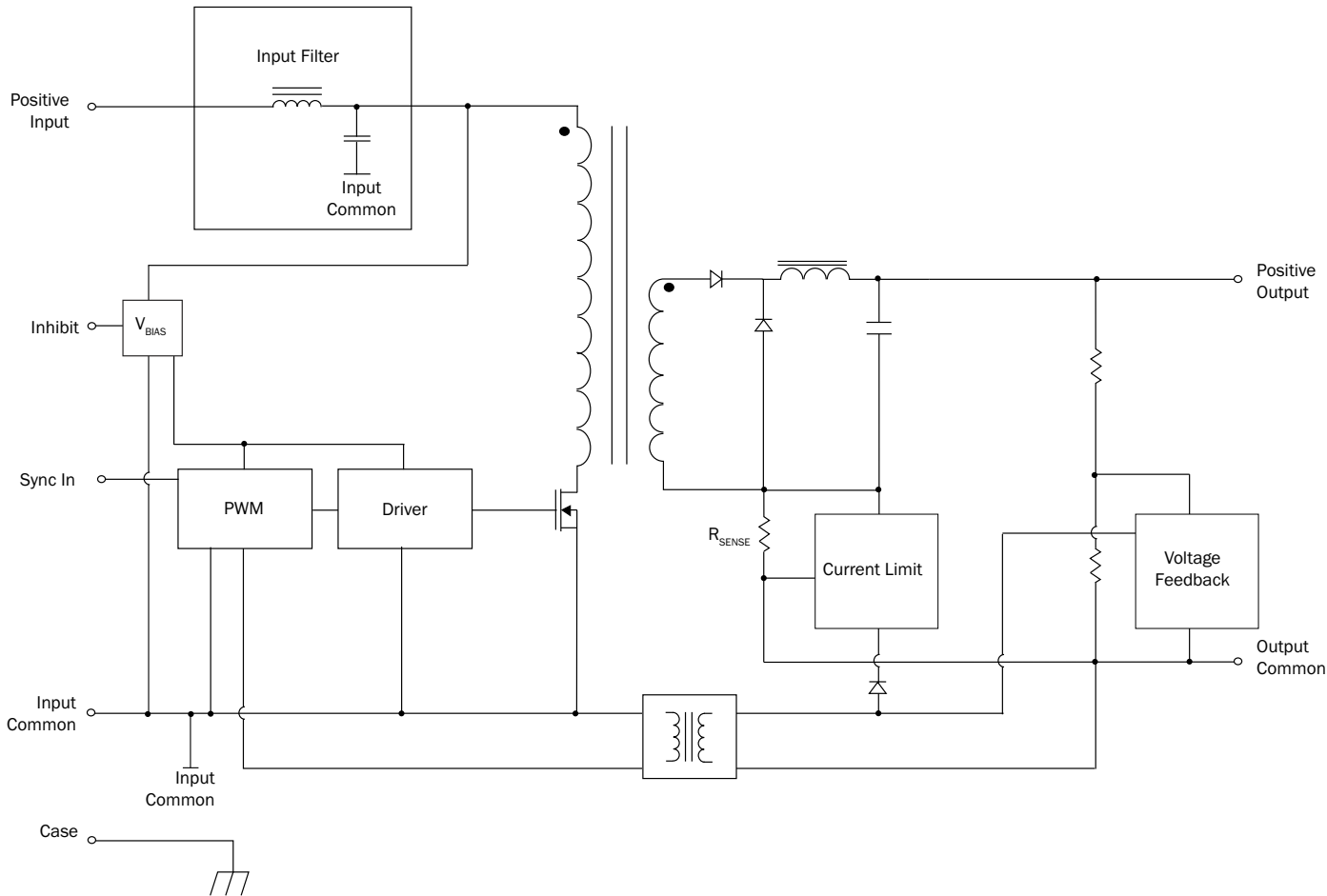

FIGURE 1: MTR SINGLE BLOCK DIAGRAM

MTR (40) Single, Dual and Triple DC-DC Converters

16 TO 40 VOLT INPUT - 20-30 WATT

MTR Series Dual Output /883

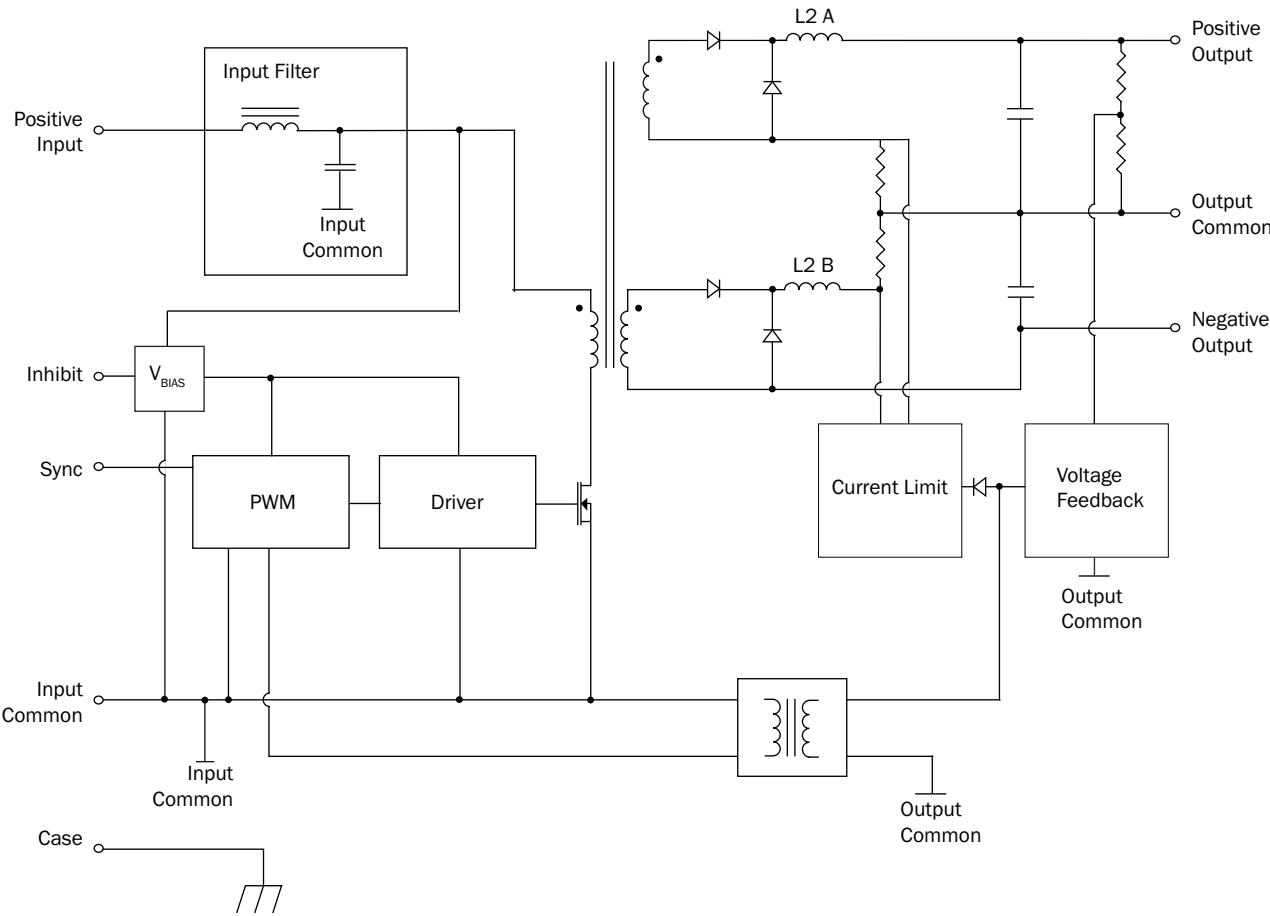

FIGURE 2: MTR DUAL /883 BLOCK DIAGRAM

MTR (40) Single, Dual and Triple DC-DC Converters

16 TO 40 VOLT INPUT - 20-30 WATT

MTR Series Dual Output non-883

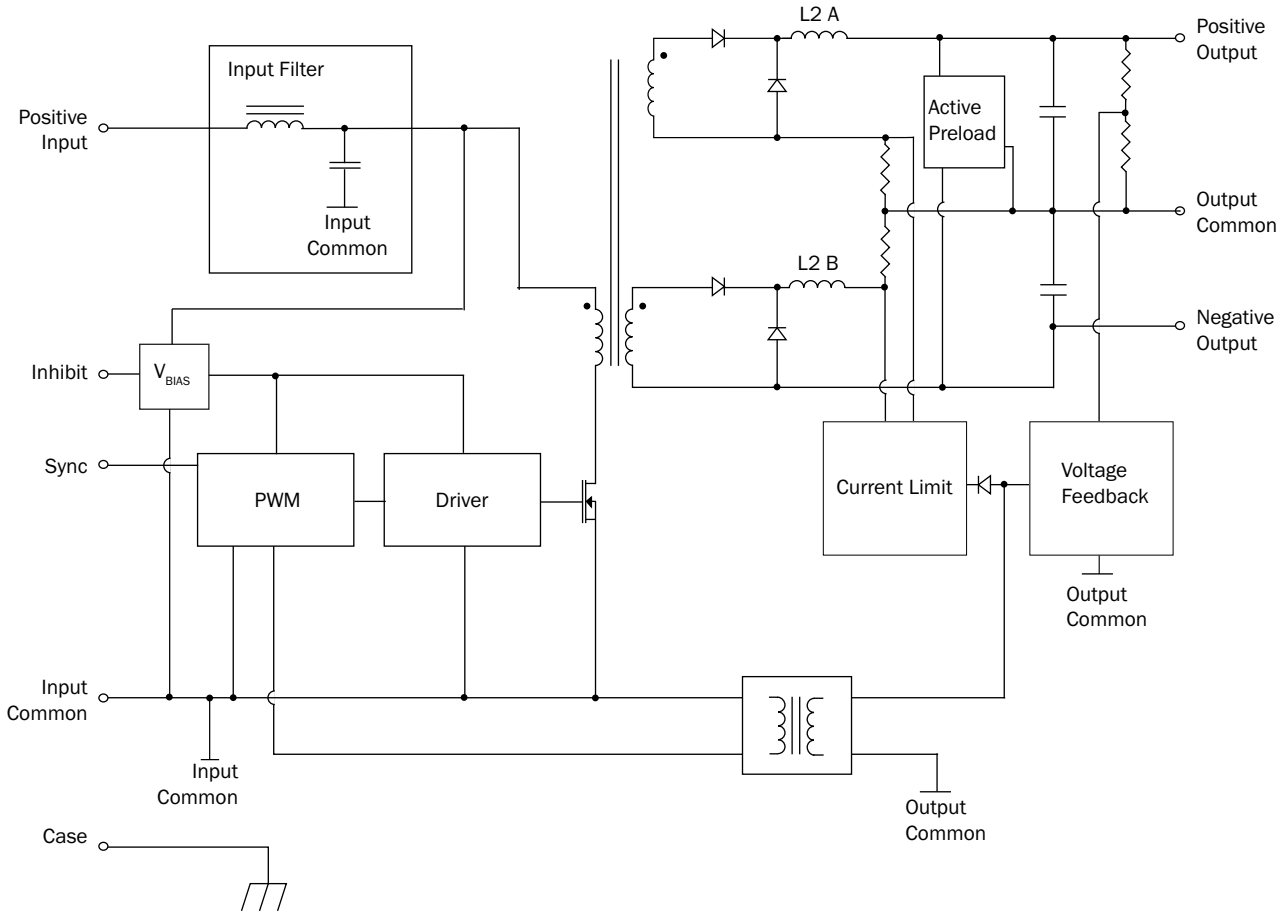

FIGURE 3: MTR DUAL NON-883 BLOCK DIAGRAM

MTR (40) Single, Dual and Triple DC-DC Converters

16 TO 40 VOLT INPUT - 20-30 WATT

MTR Series Triple Output

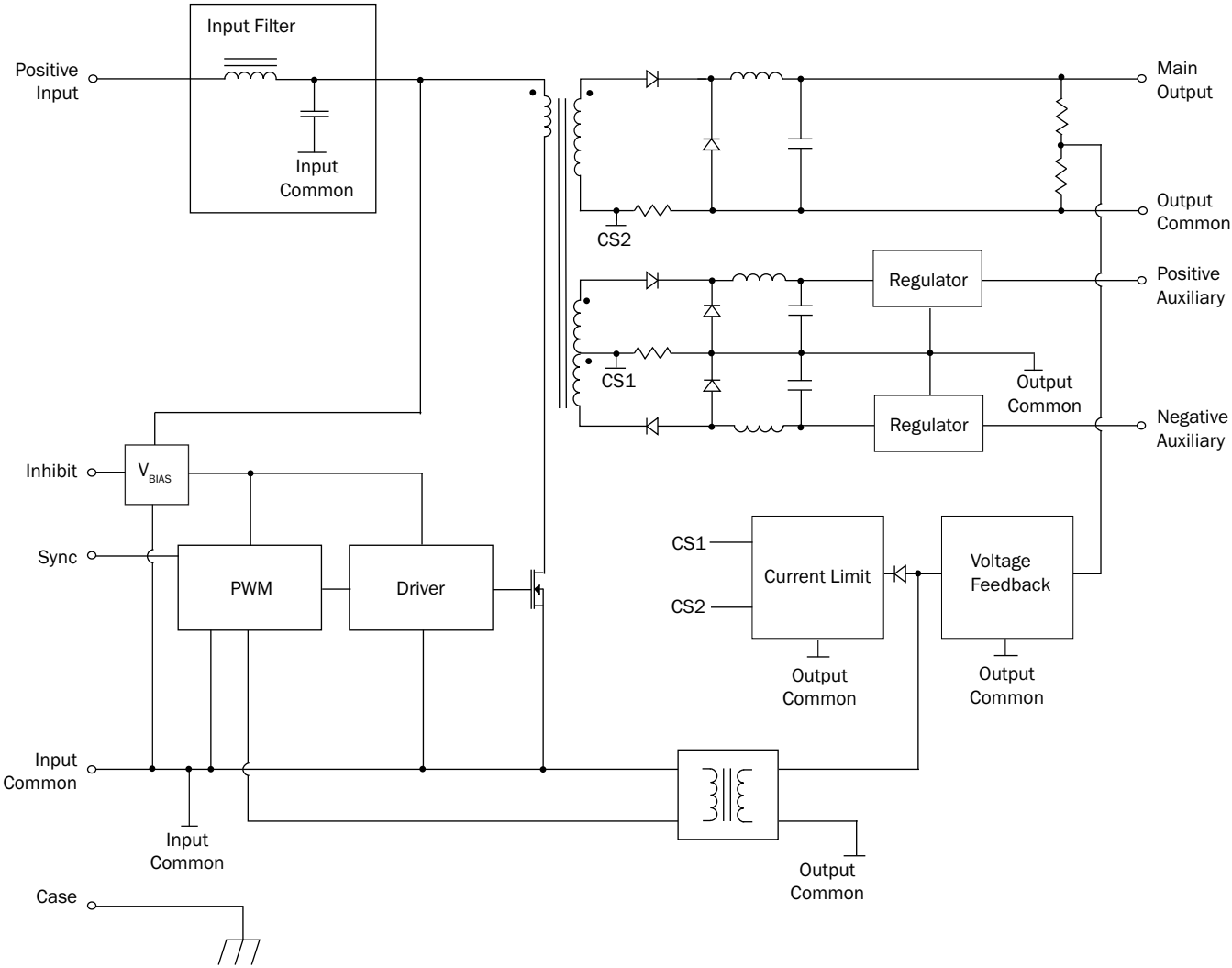

FIGURE 4: MTR TRIPLE BLOCK DIAGRAM

MTR (40) Single, Dual and Triple DC-DC Converters

16 TO 40 VOLT INPUT – 20-30 WATT

TRIM AND REMOTE SENSE (AVAILABLE ON SINGLE 3.3, 5, 8.5, 12 AND 15 OUTPUT MODELS ONLY)

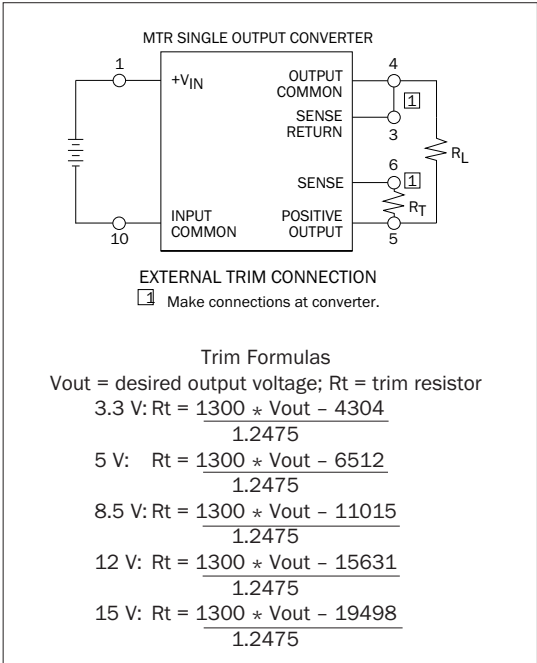

FIGURE 5: TRIM CONNECTION 1, 2, 3

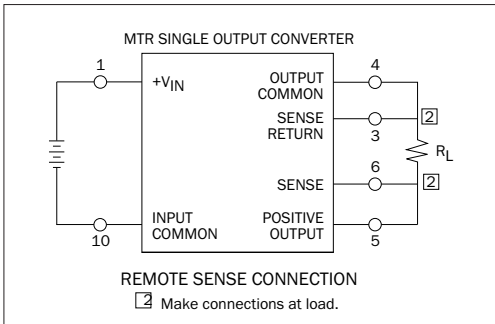
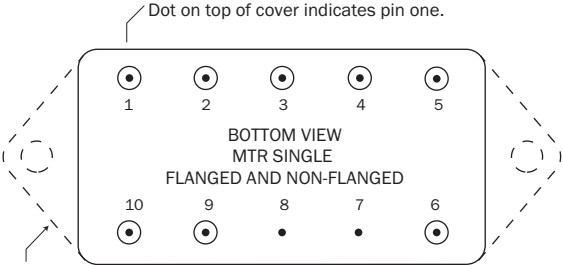

FIGURE 6: REMOTE SENSE CONNECTION 4

- Notes for Remote Sense and Trim
1. When trimming output voltage and/or using remote sense, the total output voltage increase must be less than 0.6 volts at the converters pins. Do not exceed the maximum power.
 2. If neither voltage trim nor remote sense will be used, connect pin 3 to pin 4 and pin 5 to pin 6.
 3. CAUTION: The converter will be permanently damaged if the remote sense (pin 6) is shorted to ground. Damage may also result if the output common or positive output is disconnected from the load with the remote sense leads connected to the load.
 4. When using remote sense for voltage compensation or when using remote sense for trim, the output will drift over temperature. Contact Applications Engineering for more information at powerapps@craneae.com

MTR (40) Single, Dual and Triple DC-DC Converters

16 TO 40 VOLT INPUT – 20-30 WATT



Dotted line outlines flanged package option.
See Figure 33 on page 21 and Figure 36 on page 24 for dimensions.

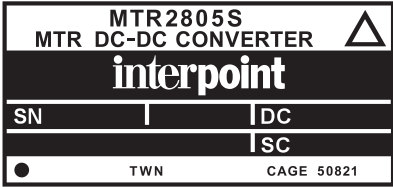

FIGURE 7: PIN OUT AND MARKING SINGLE OUTPUT MODELS

PIN OUT			
Pin	Single Output	Dual Output	Triple Output
1	Positive Input	Positive Input	Positive Input
2	Inhibit	Inhibit	Main (+5) Output
3	Sense Return	Positive Output	Output Common
4	Output Common	Output Common	Neg. Aux. Output
5	Positive Output	Negative Output	Pos. Aux. Output
6	Positive Sense	Case Ground	Case Ground
7	Case Ground	Case Ground	Case Ground
8	Case Ground	Case Ground	Inhibit
9	Sync	Sync	Sync
10	Input Common	Input Common	Input Common

TABLE 1: PIN OUT

PINS NOT IN USE	
Inhibit	Leave unconnected
Sync In	Connect to input common
Sense Lines	Must be connected to appropriate outputs

TABLE 2: PINS NOT IN USE

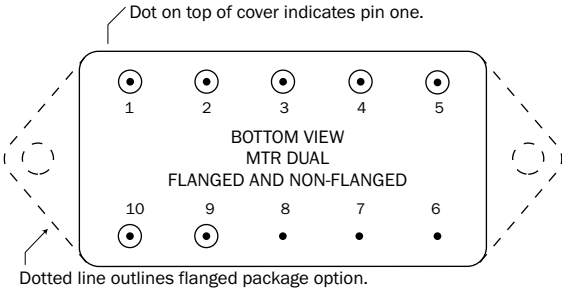

Dotted line outlines flanged package option.
See Figure 33 on page 21, Figure 34 on page 22, Figure 36 on page 24 and Figure 37 on page 25 for dimensions.



FIGURE 8: PIN OUT AND MARKING FOR DUAL OUTPUT MODELS

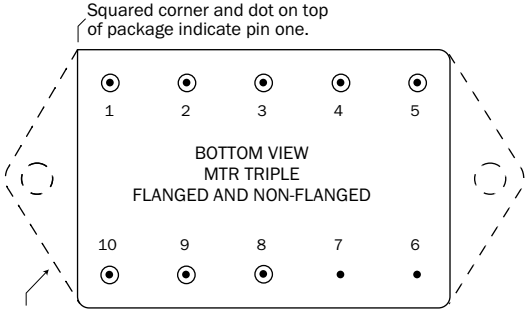

Dotted line outlines flanged package option.
See Figure 32 on page 20 and Figure 35 on page 23 for dimensions.

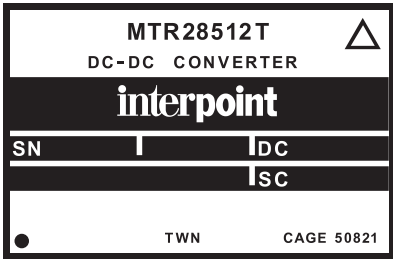

FIGURE 9: PIN OUT AND MARKING TRIPLE OUTPUT MODELS

MTR (40) Single, Dual and Triple DC-DC Converters

16 TO 40 VOLT INPUT – 20-30 WATT

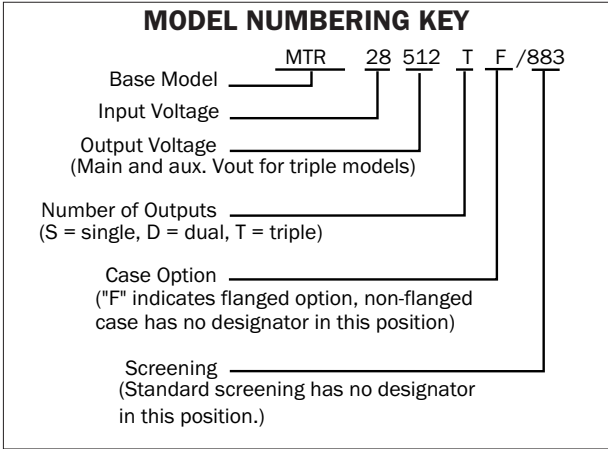

FIGURE 10: MODEL NUMBERING KEY

SMD NUMBERS	
STANDARD MICROCIRCUIT DRAWING (SMD)	MTR SIMILAR PART
5962-0150101HXC	MTR283R3S/883
5962-9306801HXC	MTR2805S/883
5962-9306901HXC	MTR2812S/883
5962-9307001HXC	MTR2815S/883
5962-9320201HXC	MTR2818S/883
5962-9320501HXC	MTR2805D/883
5962-9307101HXC	MTR2812D/883
5962-9307201HXC	MTR2815D/883
5962-9307301HXC	MTR28512T/883
5962-9307401HXC	MTR28515T/883

To indicate the flanged case option change the "X" to "Z" in the SMD number. The SMD number shown is for Class H screening, non-flanged. See the SMD for the numbers for other screening and radiation levels. For exact specifications for an SMD product, refer to the SMD drawing. SMDs can be downloaded from: <https://landandmaritimeapps.dla.mil/programs/smcr/>

TABLE 3: SMD NUMBER CROSS REFERENCE

MODEL NUMBER OPTIONS					
TO DETERMINE THE MODEL NUMBER ENTER ONE OPTION FROM EACH CATEGORY IN THE FORM BELOW.					
CATEGORY	Base Model and Input Voltage	Output Voltage ¹	Number of Outputs ²	Case Options ³	Screening ⁴
OPTIONS	MTR28	3R3, 05, 8R5, 12, 15, 18	S	(non-flanged, leave blank)	(standard, leave blank)
		05, 12, 15	D	F (flanged)	ES
		512, 515	T		883
FILL IN FOR MODEL # ⁵	MTR28	_____	_____	_____	/ _____

Notes

- Output Voltage: An R indicates a decimal point. 3R3 is 3.3 volts out. The value of 3.3, 8.5 and 18 are only available in single output models. The 512 and 515 triple output converters are +5 volt main and ±12 or ±15 volt auxiliaries.
- Number of Outputs: S is a single output, D is a dual output, and T is a triple output
- Case Options: For the standard case (Figure 33 on page 21, Figure 34 on page 22 and Figure 32 on page 20) leave the case option blank. For the flanged case option (Figure 36 on page 24, Figure 37 on page 25 and Figure 35 on page 23), insert the letter F in the Case Option position.
- Screening: For standard screening leave the screening option blank. For other screening options, insert the desired screening level. For more information see Table 13 on page 26 and Table 14 on page 27.
- If ordering by model number add suffix "-Q" to request solder dipped leads (MTR2805S/883-Q).

TABLE 4: MODEL NUMBER OPTIONS

MTR (40) Single, Dual and Triple DC-DC Converters

16 TO 40 VOLT INPUT – 20-30 WATT

TABLE 5: OPERATING CONDITIONS, ALL MODELS: 25 °C CASE, 28 VIN, 100% LOAD, UNLESS OTHERWISE SPECIFIED.

PARAMETER (Operating Conditions Table continued on next page)	CONDITIONS	ALL MODELS			UNITS
		MIN	TYP	MAX	
LEAD SOLDERING TEMPERATURE ¹	10 seconds max.	–	–	300	°C
STORAGE TEMPERATURE ¹		-65	–	+150	°C
CASE OPERATING TEMPERATURE	FULL POWER	-55	–	+125	°C
	ABSOLUTE ¹	-55	–	+135	
DERATING OUTPUT POWER/CURRENT ¹	LINEARLY	From 100% at 125 °C to 0% at 135 °C			
ESD RATING ¹ MIL-PRF-38534, 3.9.5.8.2	MIL-STD-883, METHOD 3015	0 - 1999			V
	CLASS 1 SINGLES AND TRIPLES				
	CLASS 2 DUALS	2000 - 3999			
ISOLATION: INPUT TO OUTPUT, INPUT TO CASE, OUTPUT TO CASE ²	@ 500 VDC AT 25 °C	100	–	–	Megohms
INPUT TO OUTPUT CAPACITANCE ¹	SINGLES AND DUALS	–	50	–	pF
	TRIPLES	–	100	–	
CURRENT LIMIT ³	% OF FULL LOAD	–	125	–	%
AUDIO REJECTION ¹	SINGLES AND DUALS	–	40	–	dB
	TRIPLES	–	50	–	

Notes

1. Guaranteed by design and/or analysis. Not an in-line test.
2. When testing isolation, input pins are tied together and output pins are tied together. They are tested against each other and against case. Discharge the pins before and after testing.
3. Dual and triple outputs: The over-current limit will trigger when the sum of the currents from both dual outputs or both auxiliary outputs (triple) reaches 125% (typical value) of the maximum rated "total" current of both outputs.

MTR (40) Single, Dual and Triple DC-DC Converters

16 TO 40 VOLT INPUT – 20-30 WATT

TABLE 6: OPERATING CONDITIONS, ALL MODELS: 25 °C CASE, 28 VIN, 100% LOAD, UNLESS OTHERWISE SPECIFIED.

PARAMETER (Operating Conditions Table continued)	CONDITIONS	ALL MODELS			UNITS
		MIN	TYP	MAX	
SWITCHING FREQUENCY -55 ° TO +125 °C	SINGLES AND DUALS	550	—	650	kHz
	TRIPLES	525	—	650	
SYNCHRONIZATION	INPUT FREQUENCY				kHz
	SINGLES AND DUALS	500	—	675	
	TRIPLES	500	—	700	
	DUTY CYCLE ¹	40	—	60	%
	ACTIVE LOW	—	—	0.8	V
	ACTIVE HIGH ¹	4.5	—	5.0	
	REFERENCED TO	INPUT COMMON			
IF NOT USED	CONNECT TO INPUT COMMON				
INHIBIT ACTIVE LOW (OUTPUT DISABLED) Do not apply a voltage to the inhibit pin. ²	INHIBIT PIN PULLED LOW	—	—	0.8	V
	INHIBIT PIN SOURCE CURRENT ¹				mA
	SINGLES AND DUALS	—	—	6	
	TRIPLES	—	—	8	
REFERENCED TO	INPUT COMMON				
INHIBIT ACTIVE HIGH (OUTPUT ENABLED) Do not apply a voltage to the inhibit pin. ²	INHIBIT PIN CONDITION	OPEN COLLECTOR OR UNCONNECTED			
	OPEN INHIBIT PIN VOLTAGE ¹	9	—	11	V

For mean time between failures (MTBF) contact Applications Engineering at powerapps@craneae.com or +1 425.882.3100

Notes

1. Guaranteed by design and/or analysis. Not an in-line test.
2. An external inhibit interface should be used to pull the inhibit low or leave it floating. The inhibit pin can be left unconnected if not used.

MTR (40) Single, Dual and Triple DC-DC Converters

16 TO 40 VOLT INPUT – 20-30 WATT

TABLE 7: ELECTRICAL CHARACTERISTICS -55°C TO +125°C CASE, 28 VIN, 100% LOAD, UNLESS OTHERWISE SPECIFIED.

SINGLE OUTPUT MODELS		MTR283R3S			MTR2805S			MTR288R5S			UNITS
PARAMETER	CONDITIONS	MIN	TYP	MAX	MIN	TYP	MAX	MIN	TYP	MAX	
OUTPUT VOLTAGE		3.201	3.30	3.399	4.85	5.00	5.15	8.23	8.5	8.77	V
OUTPUT CURRENT		0	–	6.06	0	–	5.0	0	–	2.95	A
OUTPUT POWER	V _{IN} = 16 TO 50 V	0	–	20	0	–	25	0	–	25	W
OUTPUT RIPPLE 10 KHZ - 2 MHZ	T _C = 25°C	–	15	40	–	35	50	–	35	60	mV p-p
	T _C = -55°C TO +125°C	–	–	50	–	50	90	–	50	90	
LINE REGULATION ²	V _{IN} = 16 TO 40 V	–	–	10	–	15	50	–	15	50	mV
LOAD REGULATION	NO LOAD TO FULL	–	–	10	–	15	50	–	15	50	mV
INPUT VOLTAGE NO LOAD TO FULL	CONTINUOUS	16	28	40	16	28	40	16	28	40	V
	TRANSIENT 50 ms ¹	–	–	50	–	–	50	–	–	50	V
INPUT CURRENT	NO LOAD	–	30	75	–	35	75	–	35	75	mA
	INHIBITED	–	7	8	–	3	8	–	3	8	
INPUT RIPPLE CURRENT ³	10 KHZ - 10 MHZ	–	25	50	–	20	50	–	20	65	mA p-p
EFFICIENCY	T _C = 25°C	74	76	–	76	78	–	78	80	–	%
	T _C = -55°C TO +125°C	71	–	–	73	–	–	78	–	–	
LOAD FAULT ^{4, 5}	POWER DISSIPATION	–	–	12	–	–	12	–	–	12	W
SHORT CIRCUIT	RECOVERY ¹	–	1.4	6	–	1.4	5	–	1.4	5	ms
STEP LOAD RESPONSE ^{5, 6} 50% - 100% - 50%	TRANSIENT	–	±125	±250	–	±200	±300	–	±300	±400	mV pk
	RECOVERY ¹	–	–	200	–	60	200	–	60	200	µs
STEP LINE RESPONSE ^{1, 5, 7} 16 - 40 -16 V	TRANSIENT	–	–	±300	–	±200	±300	–	±300	±400	mV pk
	RECOVERY	–	–	300	–	–	300	–	–	300	µs
START-UP ^{5, 8}	DELAY	–	1.4	5	–	1.4	5	–	1.4	5	m sec
FULL LOAD	OVERSHOOT ¹	–	0	50	–	0	50	–	0	50	mV pk
CAPACITIVE LOAD ¹ T _C = 25°C	NO EFFECT ON DC	–	–	300	–	–	300	–	–	300	µF
	PERFORMANCE										

Notes

1. Guaranteed by design and/or analysis. Not a production test.
2. Operation is limited below 16 volts.
3. Tested with 6800 pF ceramic bypass capacitor connected externally from input common to case.
4. Indefinite short circuit protection not guaranteed above 125°C case.

5. Recovery time is measured from application of the transient to point at which V_{OUT} is within 1% of final value.
6. Step load transition test is performed at 10 microseconds typical.
7. Step line characterization test is performed at 100 microseconds ± 20 microseconds
8. Tested on release from inhibit.

MTR (40) Single, Dual and Triple DC-DC Converters

16 TO 40 VOLT INPUT – 20-30 WATT

TABLE 8: ELECTRICAL CHARACTERISTICS -55 °C TO +125 °C CASE, 28 VIN, 100% LOAD, UNLESS OTHERWISE SPECIFIED.

SINGLE OUTPUT MODELS		MTR2812S			MTR2815S			MTR2818S			UNITS
PARAMETER	CONDITIONS	MIN	TYP	MAX	MIN	TYP	MAX	MIN	TYP	MAX	
OUTPUT VOLTAGE		11.64	12.00	12.36	14.70	15.00	15.30	17.46	18.00	18.54	V
OUTPUT CURRENT		0	–	2.5	0	–	2.0	0	–	1.67	A
OUTPUT POWER	V _{IN} = 16 TO 50 V	0	–	30	0	–	30	0	–	30	W
OUTPUT RIPPLE 10 KHZ - 2 MHZ	T _C = 25 °C	–	25	40	–	25	40	–	–	40	mV p-p
	T _C = -55 °C TO +125 °C	–	40	90	–	40	90	–	–	90	
LINE REGULATION ²	V _{IN} = 16 TO 40 V	–	15	50	–	15	50	–	–	50	mV
LOAD REGULATION	NO LOAD TO FULL	–	15	50	–	15	50	–	–	50	mV
INPUT VOLTAGE NO LOAD TO FULL	CONTINUOUS	16	28	40	16	28	40	16	28	40	V
	TRANSIENT 50 ms ¹	–	–	50	–	–	50	–	–	50	V
INPUT CURRENT	NO LOAD	–	35	75	–	35	75	–	–	75	mA
	INHIBITED	–	3	8	–	3	8	–	–	8	
INPUT RIPPLE CURRENT ³	10 KHZ - 10 MHZ	–	20	50	–	20	50	–	–	50	mA p-p
EFFICIENCY	T _C = 25 °C	80	83	–	81	84	–	81	84	–	%
	T _C = -55 °C TO +125 °C	77	–	–	78	–	–	78	–	–	
LOAD FAULT ^{4, 5}	POWER DISSIPATION	–	–	12	–	–	12	–	–	12	W
SHORT CIRCUIT	RECOVERY ¹	–	1.4	5	–	1.4	5	–	1.4	5	ms
STEP LOAD RESPONSE ^{5, 6} 50% - 100% - 50%	TRANSIENT	–	±250	±400	–	±350	±500	–	–	±600	mV pk
	RECOVERY ¹	–	60	200	–	60	200	–	60	200	
STEP LINE RESPONSE ^{1, 5, 7} 16 - 40 -16 V	TRANSIENT	–	±400	±625	–	±500	±750	–	±500	±800	mV pk
	RECOVERY	–	–	350	–	–	350	–	–	350	
START-UP ^{5, 8}	DELAY	–	1.4	5	–	1.4	5	–	–	5	m sec
FULL LOAD	OVERSHOOT ¹	–	0	120	–	0	150	–	0	180	mV pk
CAPACITIVE LOAD ¹ T _C = 25 °C	NO EFFECT ON DC PERFORMANCE	–	–	300	–	–	300	–	–	300	µF

Notes

1. Guaranteed by design and/or analysis. Not a production test.
2. Operation is limited below 16 volts.
3. Tested with 6800 pF ceramic bypass capacitor connected externally from input common to case.
4. Indefinite short circuit protection not guaranteed above 125 °C case.

5. Recovery time is measured from application of the transient to point at which V_{OUT} is within 1% of final value.
6. Step load transition test is performed at 10 microseconds typical.
7. Step line characterization test is performed at 100 microseconds ± 20 microseconds
8. Tested on release from inhibit.

MTR (40) Single, Dual and Triple DC-DC Converters

16 TO 40 VOLT INPUT – 20-30 WATT

TABLE 9: ELECTRICAL CHARACTERISTICS -55 °C TO +125 °C CASE, 28 VIN, 100% LOAD, UNLESS OTHERWISE SPECIFIED.

DUAL OUTPUT MODELS - /883 ONLY		MTR2805D			MTR2812D			MTR2815D			UNITS
PARAMETER	CONDITIONS	MIN	TYP	MAX	MIN	TYP	MAX	MIN	TYP	MAX	
OUTPUT VOLTAGE	+ V _{OUT}	4.850	5.00	5.150	11.64	12.00	12.36	14.55	15.00	15.45	V
	- V _{OUT}	4.825	5.00	5.172	11.58	12.00	12.42	14.47	15.00	15.53	
OUTPUT CURRENT ² V _{IN} = 16 TO 40 V	EITHER OUTPUT	0	2.5	4.5 ¹	0	1.25	2.25 ¹	0	1.00	1.80 ¹	A
	TOTAL OUTPUT	—	—	5	—	—	2.5	—	—	2.00	
OUTPUT POWER ² V _{IN} = 16 TO 40 V	EITHER OUTPUT	0	12.5	22.5 ¹	0	15	27 ¹	0	15	27 ¹	W
	TOTAL OUTPUT	—	—	25	—	—	30	—	—	30	
OUTPUT RIPPLE 10 KHZ - 2 MHZ ± V _{OUT}	T _C = 25 °C	—	20	40	—	30	80	—	25	80	mV p-p
	T _C = -55 °C TO +125 °C	—	40	90	—	40	120	—	40	120	
LINE REGULATION ³ V _{IN} = 16 TO 40 V	+ V _{OUT}	—	10	50	—	10	50	—	10	50	mV
	- V _{OUT}	—	50	100	—	50	150	—	50	180	
LOAD REGULATION NO LOAD TO FULL	+ V _{OUT}	—	5	50	—	15	50	—	15	50	mV
	- V _{OUT}	—	25	100	—	30	150	—	30	180	
CROSS REGULATION ¹ EFFECT ON -V _{OUT} , 25 °C	SEE NOTE 4	—	4	6	—	4	6	—	4	6	%
	SEE NOTE 5	—	7	12	—	4	8.3	—	3	8	
INPUT VOLTAGE NO LOAD TO FULL	CONTINUOUS	16	28	40	16	28	40	16	28	40	V
	TRANSIENT 50 ms ¹	0	—	50	0	—	50	0	—	50	
INPUT CURRENT	NO LOAD	—	35	75	—	50	75	—	50	75	mA
	INHIBITED	—	3	8	—	3	8	—	3	8	
INPUT RIPPLE CURRENT ⁶ 10 KHZ - 10 MHZ		—	15	50	—	20	50	—	20	50	mA p-p
EFFICIENCY BALANCED LOAD	T _C = 25 °C	76	78	—	79	81	—	80	83	—	%
	T _C = -55 °C TO +125 °C	73	—	—	76	—	—	77	—	—	
LOAD FAULT ^{7, 8} SHORT CIRCUIT	POWER DISSIPATION	—	10	12	—	10	12	—	10	12	W
	RECOVERY ¹	—	1.4	5.0	—	1.4	5.0	—	1.4	5.0	ms
STEP LOAD RESPONSE ^{8, 9} 50% - 100% - 50% ± V _{OUT}	TRANSIENT	—	±200	±300	—	±150	±300	—	±200	±400	mV pk
	RECOVERY ¹	—	100	200	—	100	200	—	100	200	µs
STEP LINE RESPONSE ^{1, 8, 10} V _{IN} = 16 TO 40 V ± V _{OUT}	TRANSIENT	—	±200	±400	—	±200	±400	—	±400	±500	mV pk
	RECOVERY	—	—	300	—	—	300	—	—	300	µs
START-UP FULL LOAD	DELAY	—	1.4	5	—	1.4	5	—	1.4	5	ms
	OVERSHOOT ¹	—	0	180	—	0	120	—	0	150	mV pk
CAPACITIVE LOAD ^{1, 12} T _C = 25 °C	NO EFFECT ON DC	—	—	500	—	—	500	—	—	500	µF
	PERFORMANCE										

Notes

- Guaranteed by design and/or analysis. Not a production test.
- Up to 90% of the total output current/power is available from either output providing the opposite output is carrying at least 10% of the total output power.
- Operation is limited below 16 volts.
- Effect on negative V_{OUT} from 50%/50% loads to 80%/20% or 20%/80% loads.
- Effect on negative V_{OUT} from 50%/50% loads to 90%/10% or 10%/90% loads. Figure 23 on page 18.
- Tested with 6800 pF ceramic bypass capacitor connected externally from input common to case.

- Indefinite short circuit protection not guaranteed above 125 °C case.
- Recovery time is measured from application of the transient to point at which V_{OUT} is within 1% of final value.
- Step load transition test is performed at 10 microseconds typical.
- Step line characterization test is performed at 100 microseconds ± 20 microseconds
- Tested on release from inhibit.
- Applies to each output.

MTR (40) Single, Dual and Triple DC-DC Converters

16 TO 40 VOLT INPUT – 20-30 WATT

TABLE 10: ELECTRICAL CHARACTERISTICS -55 °C TO +125 °C CASE, 28 VIN, 100% LOAD, UNLESS OTHERWISE SPECIFIED.

DUAL OUTPUT MODELS - STANDARD AND /ES		MTR2805D ²			MTR2812D			MTR2815D			UNITS
PARAMETER	CONDITIONS	MIN	TYP	MAX	MIN	TYP	MAX	MIN	TYP	MAX	
OUTPUT VOLTAGE	+ V _{OUT}	4.850	5.00	5.150	11.64	12.00	12.36	14.55	15.00	15.45	V
	- V _{OUT}	4.825	5.00	5.172	11.58	12.00	12.42	14.47	15.00	15.53	
OUTPUT CURRENT ³ V _{IN} = 16 TO 40 V	EITHER OUTPUT	0	2.5	4.5 ¹	0	1.25	2.25 ¹	0	1.00	1.80 ¹	A
	TOTAL OUTPUT	—	—	5	—	—	2.5	—	—	2.00	
OUTPUT POWER ³ V _{IN} = 16 TO 40 V	EITHER OUTPUT	0	12.5	22.5 ¹	0	15	27 ¹	0	15	27 ¹	W
	TOTAL OUTPUT	—	—	25	—	—	30	—	—	30	
OUTPUT RIPPLE 10 KHZ - 2 MHZ ± V _{OUT}	T _C = 25 °C	—	20	80	—	30	80	—	25	80	MV P-P
	T _C = -55 °C TO +125 °C	—	—	—	—	40	120	—	40	120	
LINE REGULATION ⁴ V _{IN} = 16 TO 40 V	+ V _{OUT}	—	10	50	—	10	50	—	10	50	MV
	- V _{OUT}	—	50	100	—	50	150	—	50	180	
LOAD REGULATION NO LOAD TO FULL	+ V _{OUT}	—	5	50	—	15	50	—	15	50	MV
	- V _{OUT}	—	25	100	—	30	150	—	30	180	
CROSS REGULATION ¹ EFFECT ON -V _{OUT} , 25 °C	SEE NOTE 5	—	4	6	—	4	6	—	4	6	%
	SEE NOTE 6	—	7	12	—	4	8.3	—	3	8	
INPUT VOLTAGE NO LOAD TO FULL	CONTINUOUS	16	28	40	16	28	40	16	28	40	V
	TRANSIENT 50 ms ¹	0	—	50	0	—	50	0	—	50	
INPUT CURRENT	NO LOAD	—	35	50	—	50	75	—	50	75	mA
	INHIBITED	—	3	8	—	3	8	—	3	8	
INPUT RIPPLE CURRENT ⁷	10 KHZ - 10 MHZ	—	15	40	—	20	50	—	20	50	MA P-P
EFFICIENCY BALANCED LOAD	T _C = 25 °C	76	78	—	78	81	—	80	83	—	%
	T _C = -55 °C TO +125 °C	—	—	—	76	—	—	77	—	—	
LOAD FAULT ^{8, 9}	POWER DISSIPATION	—	10	12	—	10	12	—	10	12	W
SHORT CIRCUIT	RECOVERY ¹	—	1.4	5.0	—	1.4	5.0	—	1.4	5.0	MS
STEP LOAD RESPONSE ^{9, 10} 50% - 100% - 50% ± V _{OUT}	TRANSIENT	—	±200	±300	—	±150	±300	—	±200	±400	MV PK
	RECOVERY ¹	—	100	200	—	100	200	—	100	200	S
STEP LINE RESPONSE ^{1, 9, 11} V _{IN} = 16 TO 40 V ± V _{OUT}	TRANSIENT	—	±200	±400	—	±200	±400	—	±400	±500	MV PK
	RECOVERY	—	—	300	—	—	300	—	—	300	S
START-UP ^{9, 12} FULL LOAD	DELAY	—	1.4	5	—	1.4	5	—	1.4	5	ms
	OVERSHOOT ¹	—	0	180	—	0	120	—	0	150	mV pk
CAPACITIVE LOAD ^{1, 13} T _C = 25 °C	NO EFFECT ON DC	—	—	500	—	—	500	—	—	500	µF
	PERFORMANCE	—	—	500	—	—	500	—	—	500	

Notes

- Guaranteed by design and/or analysis. Not a production test.
- MTR2805D (standard and /ES) is specified at 25 °C only.
- Up to 90% of the total output current/power is available from either output providing the opposite output is carrying at least 10% of the total output power.
- Operation is limited below 16 volts.
- Effect on negative V_{OUT} from 50%/50% loads to 80%/20% or 20%/80% loads.
- Effect on negative V_{OUT} from 50%/50% loads to 90%/10% or 10%/90% loads. Figure 23 on page 18
- Tested with 6800 pF ceramic bypass capacitor connected externally from input common to case.

- Indefinite short circuit protection not guaranteed above 125 °C case.
- Recovery time is measured from application of the transient to point at which V_{OUT} is within 1% of final value.
- Step load transition test is performed at 10 microseconds typical.
- Step line characterization test is performed at 100 microseconds ± 20 microseconds
- Tested on release from inhibit.
- Applies to each output.

MTR (40) Single, Dual and Triple DC-DC Converters

16 TO 40 VOLT INPUT – 20-30 WATT

TABLE 11: ELECTRICAL CHARACTERISTICS -55 °C TO +125 °C CASE, 28 VIN, 100% LOAD, UNLESS OTHERWISE SPECIFIED.

TRIPLE OUTPUT MODEL – MTR28512T		5 (MAIN)			±12 (AUXILIARIES)			UNITS
PARAMETER	CONDITIONS	MIN	TYP	MAX	MIN	TYP	MAX	
OUTPUT VOLTAGE		4.85	5.00	5.15	±11.58	12.00	±12.42	V
OUTPUT CURRENT ²		0.3	–	4.0	0	±0.416	0.750 ₁	A
V _{IN} = 16 TO 40 V	MAX TOTAL AUX	–	–	–	–	–	0.833	
OUTPUT POWER ²		0	–	20	0	±5	9.00 ¹	W
V _{IN} = 16 TO 40 V	MAX TOTAL AUX	–	–	–	–	–	10	
OUTPUT RIPPLE	T _C = 25 °C	–	50	125	–	20	60	mV p-p
10 KHZ - 2 MHZ	T _C = -55 °C TO +125 °C	–	–	180	–	–	60	
LINE REGULATION	V _{IN} = 16 TO 40 V	–	10	20	–	25	75	mV
LOAD REGULATION ^{3, 4}		–	10	50	–	30	75	mV
INPUT VOLTAGE	CONTINUOUS	16	28	40	–	–	–	V
	TRANSIENT 50 MS ¹	–	–	50	–	–	–	V
INPUT CURRENT	NO LOAD	–	70	110	–	–	–	mA
	INHIBITED	–	3.0	6	–	–	–	
INPUT RIPPLE CURRENT	10 KHZ - 10 MHZ	–	20	80	–	–	–	mA p-p
EFFICIENCY	T _C = 25 °C	72	75	–	–	–	–	%
	T _C = -55 °C TO +125 °C	70	–	–	–	–	–	
LOAD FAULT ^{5, 7}	POWER DISSIPATION	–	–	14	–	–	14	W
ALL OUTPUTS SHORTED	RECOVERY ¹	–	4	6.0	–	4	6.0	ms
STEP LOAD RESPONSE ^{6, 7, 8}	TRANSIENT	–	–	±400	–	–	±1500	mV pk
50% - 100% - 50% each output	RECOVERY ¹	–	–	0.300	–	–	6	ms
STEP LINE RESPONSE ^{1, 7, 9}	TRANSIENT	–	–	±800	–	–	±800	mV pk
16 - 40 - 16 V _{IN}	RECOVERY	–	–	5	–	–	5	ms
START-UP ^{7, 10}	DELAY	–	4	6.0	–	4	6.0	ms
	OVERSHOOT ¹	–	–	500	–	–	1500	mV pk

Notes

- Guaranteed by design and/or analysis. Not a production test.
- The sum of the two aux outputs is not to exceed 10 watts. The maximum load per aux output is 9 watts.
- To maintain regulation when operating the ±aux at full load, a minimum load of 300 mA is required on the main.
- Measured on each output one at a time with the other outputs at full load.
- Indefinite short circuit protection not guaranteed above 125 °C (case).
- Response of each output as all outputs are simultaneously transitioned.
Main: 50% - 100% - 50% of main full load
Auxiliaries: 25% - 50% - 25% each, of total auxiliary full load

- Recovery time is measured from application of the transient to point at which V_{OUT} is within 1% of regulation.
- Step load transition test is performed at 10 microseconds typical.
- Step line characterization test is performed at 100 microseconds ± 20 microseconds
- Tested on release from inhibit.

MTR (40) Single, Dual and Triple DC-DC Converters

16 TO 40 VOLT INPUT – 20-30 WATT

TABLE 12: ELECTRICAL CHARACTERISTICS -55 °C TO +125 °C CASE, 28 VIN, 100% LOAD, UNLESS OTHERWISE SPECIFIED.

TRIPLE OUTPUT MODEL – MTR28515T		5 (MAIN)			±15 (AUXILIARIES)			UNITS
PARAMETER	CONDITIONS	MIN	TYP	MAX	MIN	TYP	MAX	
OUTPUT VOLTAGE		4.85	5.00	5.15	±14.47	15.00	±15.52	V
OUTPUT CURRENT ²		0.3	–	4.0	0	±0.333	0.600 1	A
V _{IN} = 16 TO 40 V	MAX TOTAL AUX	–	–	–	–	–	0.666	
OUTPUT POWER ²		0	–	20	0	±5	9.00 ¹	W
V _{IN} = 16 TO 40 V	MAX TOTAL AUX	–	–	–	–	–	10	
OUTPUT RIPPLE	T _C = 25 °C	–	50	125	–	20	60	mV p-p
10 KHZ - 2 MHZ	T _C = -55 °C TO +125 °C	–	–	180	–	–	60	
LINE REGULATION	V _{IN} = 16 TO 40 V	–	10	20	–	30	75	mV
LOAD REGULATION ^{3, 4}		–	10	50	–	30	75	mV
INPUT VOLTAGE	CONTINUOUS	16	28	40	–	–	–	V
	TRANSIENT 50 MS ¹	–	–	50	–	–	–	V
INPUT CURRENT	NO LOAD	–	70	120	–	–	–	mA
	INHIBITED	–	3.0	6	–	–	–	
INPUT RIPPLE CURRENT	10 KHZ - 10 MHZ	–	20	80	–	–	–	mA p-p
EFFICIENCY	T _C = 25 °C	73	75	–	–	–	–	%
	T _C = -55 °C TO +125 °C	71	–	–	–	–	–	
LOAD FAULT ^{5, 7}	POWER DISSIPATION	–	–	14	–	–	14	W
ALL OUTPUTS SHORTED	RECOVERY ¹	–	4	6.0	–	4	6.0	ms
STEP LOAD RESPONSE ^{6, 7, 9}	TRANSIENT	–	–	±400	–	–	±1500	mV pk
	50% - 100% - 50% each output	RECOVERY	–	–	0.300	–	–	6
STEP LINE RESPONSE ^{1, 7, 8}	TRANSIENT	–	–	±800	–	–	±800	mV pk
	16 - 40 - 16 V _{IN}	RECOVERY ⁷	–	–	5	–	–	5
START-UP ^{7, 10}	DELAY	–	4	6.0	–	4	6.0	ms
	OVERSHOOT ¹	–	–	500	–	–	1500	mV pk

Notes

- Guaranteed by design and/or analysis. Not a production test.
- The sum of the two aux outputs is not to exceed 10 watts. The maximum load per aux output is 9 watts.
- To maintain regulation when operating the ±aux at full load, a minimum load of 300 mA is required on the main.
- Measured on each output one at a time with the other outputs at full load.
- Indefinite short circuit protection not guaranteed above 125 °C (case).
- Response of each output as all outputs are simultaneously transitioned.
Main: 50% - 100% - 50% of main full load
Auxiliaries: 25% - 50% - 25% each, of total auxiliary full load

- Recovery time is measured from application of the transient to point at which V_{OUT} is within 1% of regulation.
- Step load transition test is performed at 10 microseconds typical.
- Step line characterization test is performed at 100 microseconds ± 20 microseconds
- Tested on release from inhibit.

MTR (40) Single, Dual and Triple DC-DC Converters

16 TO 40 VOLT INPUT - 20-30 WATT

Typical Performance Plots: 28 Vin, 25 °C Case, 100% load, unless otherwise specified.
These are examples for reference only and are not guaranteed specifications.

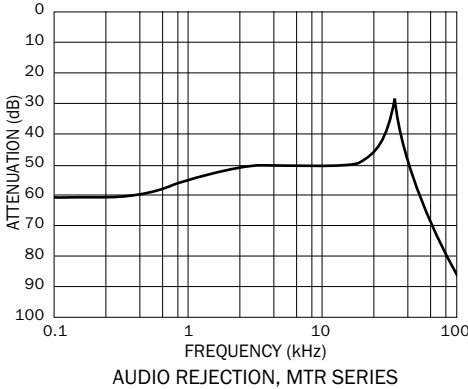

FIGURE 11

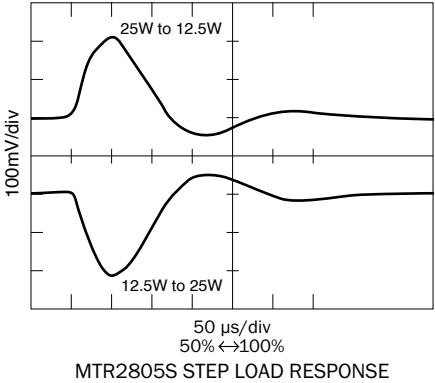

FIGURE 12

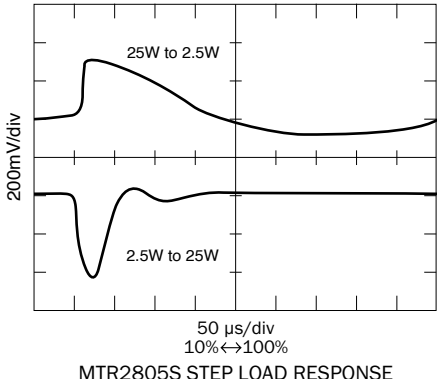

FIGURE 13

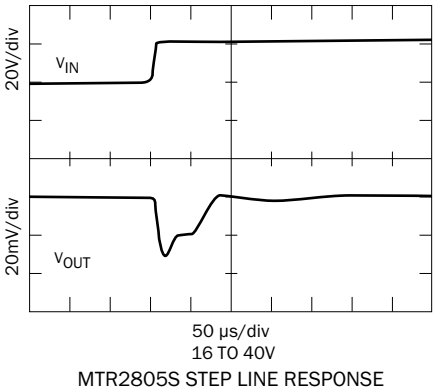

FIGURE 14

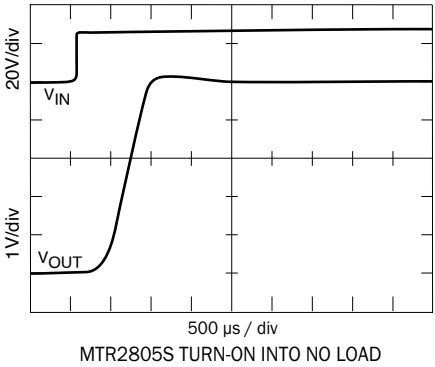

FIGURE 15

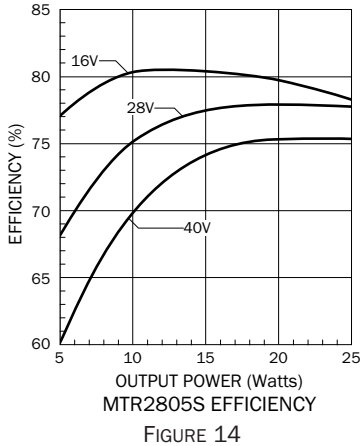

FIGURE 14

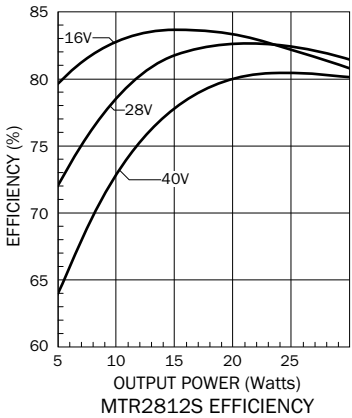

FIGURE 16

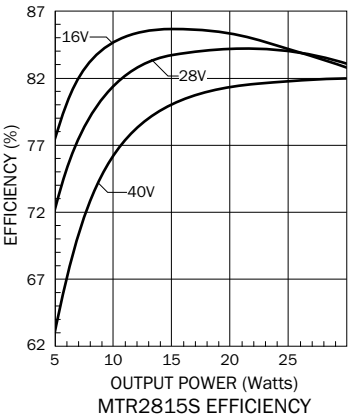
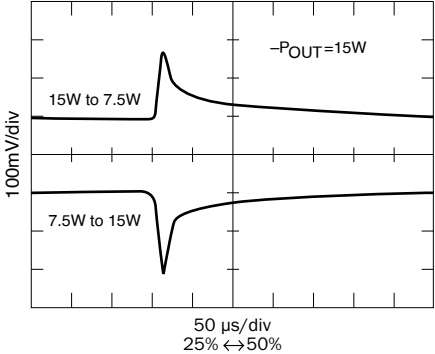

FIGURE 17

MTR (40) Single, Dual and Triple DC-DC Converters

16 TO 40 VOLT INPUT - 20-30 WATT

Typical Performance Plots: 28 Vin, 25 °C Case, 100% load, unless otherwise specified.
 These are examples for reference only and are not guaranteed specifications.



MTR2815D +V_{OUT} STEP LOAD RESPONSE
 FIGURE 18

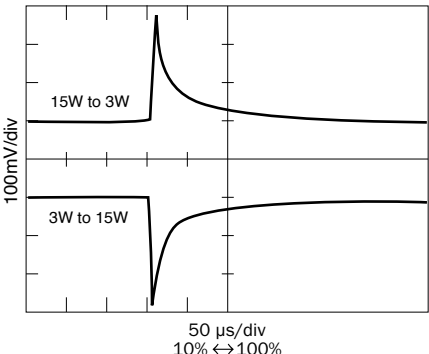

MTR2815D +V_{OUT} STEP LOAD RESPONSE
 FIGURE 19

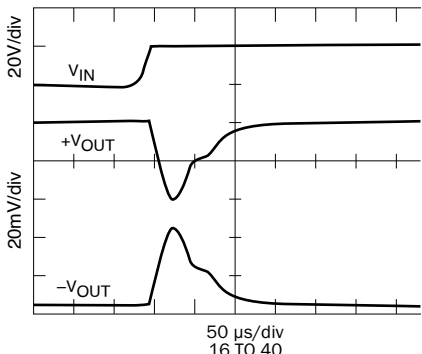

MTR2815D STEP LINE RESPONSE
 FIGURE 20

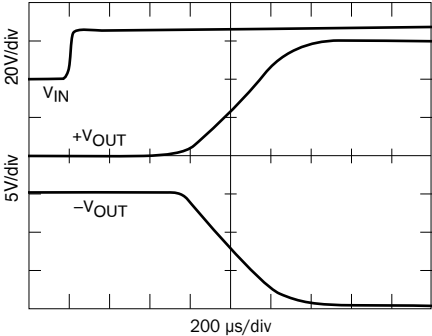

MTR2815D TURN-ON INTO NO LOAD
 FIGURE 21

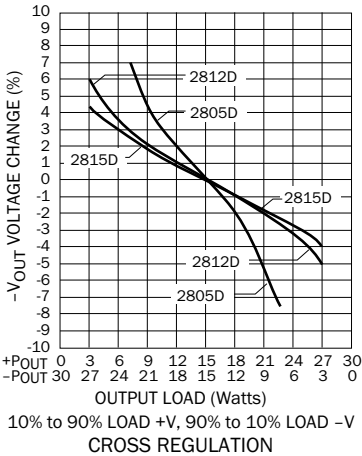

FIGURE 22

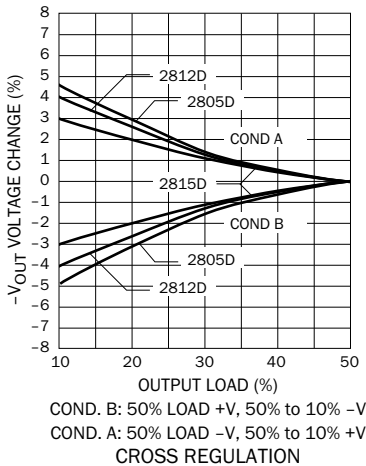

FIGURE 23

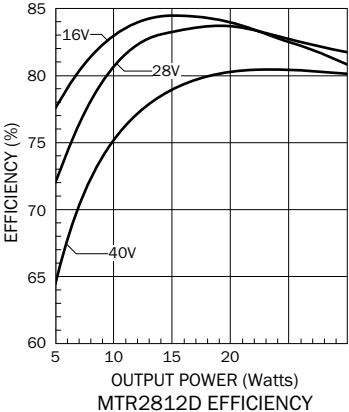

FIGURE 24

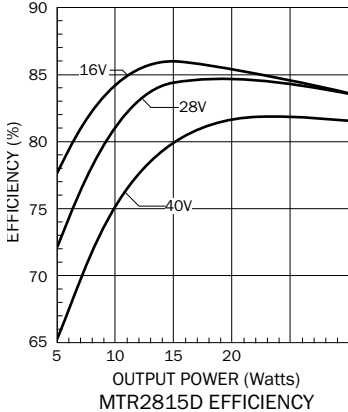
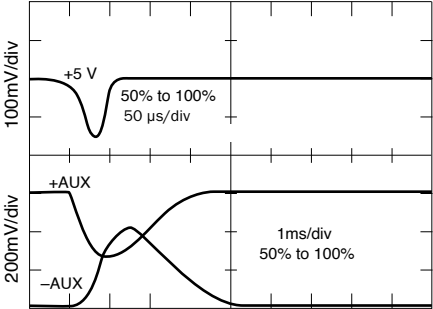

FIGURE 25

MTR (40) Single, Dual and Triple DC-DC Converters

16 TO 40 VOLT INPUT - 20-30 WATT

Typical Performance Plots: 28 Vin, 25 °C Case, 100% load, unless otherwise specified.
These are examples for reference only and are not guaranteed specifications.



50% ↔ 100%
MTR28515T STEP LOAD RESPONSE

FIGURE 26

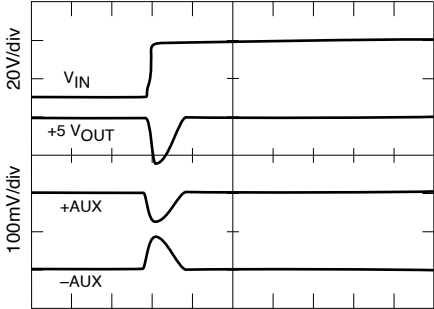

50 µs/div
16V TO 40V
MTR28515T STEP LINE RESPONSE

FIGURE 27

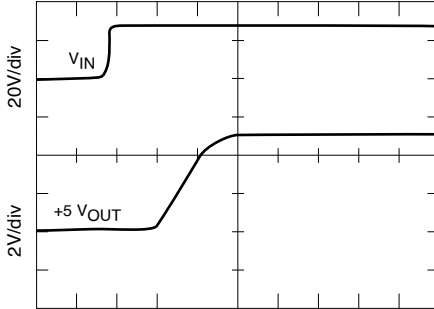

500 µs/div
MTR28515T, MAIN (+5)
TURN-ON INTO FULL LOAD

FIGURE 28

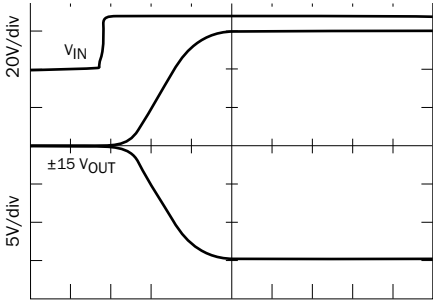

500 µs/div
MTR28515T, AUX. (±15)
TURN-ON INTO FULL LOAD

FIGURE 29

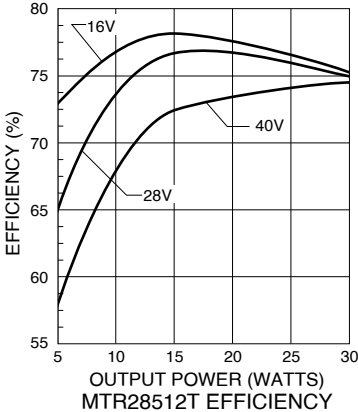

MTR28512T EFFICIENCY

FIGURE 30

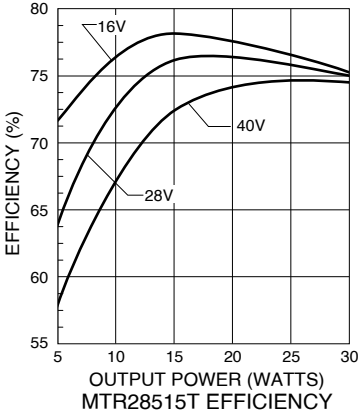

MTR28515T EFFICIENCY

FIGURE 31

MTR (40) Single, Dual and Triple DC-DC Converters

16 TO 40 VOLT INPUT - 20-30 WATT

BOTTOM VIEW CASE F1

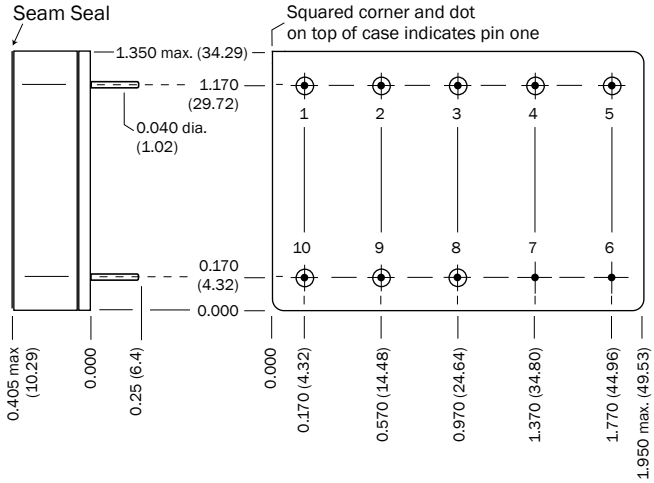

Weight: 58 grams maximum

Case dimensions in inches (mm)
 Tolerance ± 0.005 (0.13) for three decimal places
 ± 0.01 (0.3) for two decimal places
 unless otherwise specified

CAUTION
 Heat from reflow or wave soldering may damage the device.
 Solder pins individually with heat application not exceeding 300 °C for 10 seconds per pin.

Materials
 Header Cold Rolled Steel/Nickel/Gold
 Cover Kovar/Nickel
 Pins #52 alloy/Gold ceramic seal
 Gold plating of 50 - 150 microinches included in pin diameter
 Seal hole 0.120 ± 0.002 (3.05 ± 0.05)

Please refer to the numerical dimensions for accuracy.

FIGURE 32: CASE F1 - TRIPLE MODELS

MTR (40) Single, Dual and Triple DC-DC Converters

16 TO 40 VOLT INPUT - 20-30 WATT

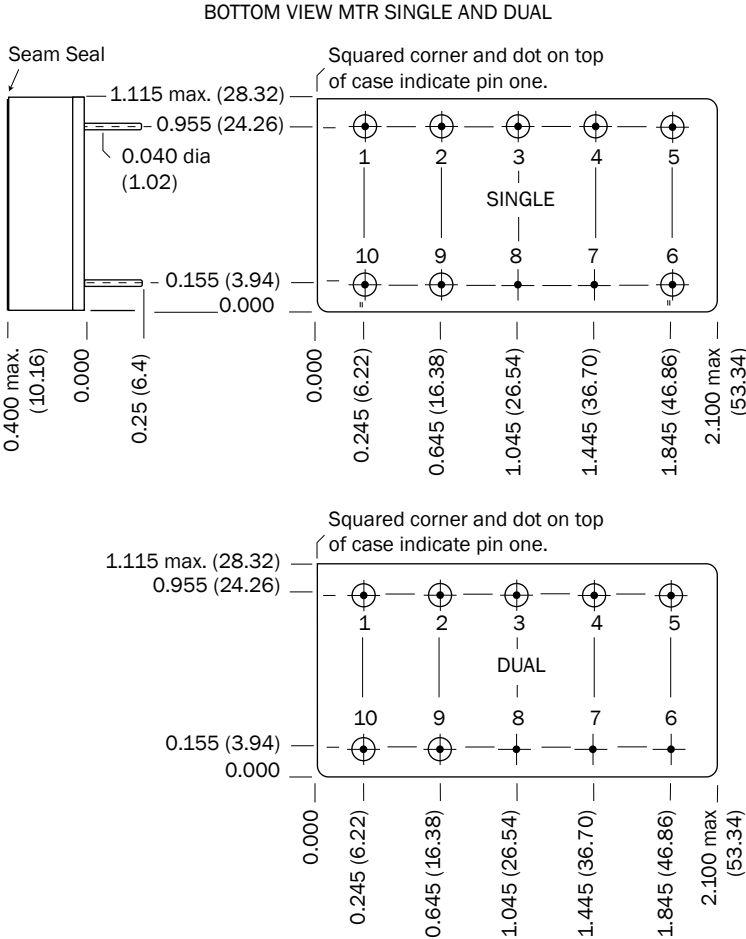

Weight: 50 grams

Case dimensions in inches (mm)
Tolerance ± 0.005 (0.13) for three decimal places
 ± 0.01 (0.3) for two decimal places
unless otherwise specified

CAUTION
Heat from reflow or wave soldering may damage the device.
Solder pins individually with heat application not exceeding 300 °C for 10 seconds p

Materials
Header Cold Rolled Steel/Nickel/Gold
Cover Kovar/Nickel
Pins #52 alloy/Gold ceramic seal
Gold plating of 50 - 150 microinches included in pin diameter
Seal hole 0.120 ± 0.002 (3.05 ± 0.05)

Please refer to the numerical dimensions for accuracy.

FIGURE 33: CASE H2 - SINGLE AND 883 DUAL MODELS
APPLIES TO ALL SINGLE MODELS, APPLIES ONLY TO 883 DUAL MODELS, SEE FIGURE 34 ON PAGE 22, CASE H4, FOR NON-883 DUAL MODELS

MTR (40) Single, Dual and Triple DC-DC Converters

16 TO 40 VOLT INPUT - 20-30 WATT

BOTTOM VIEW CASE H4

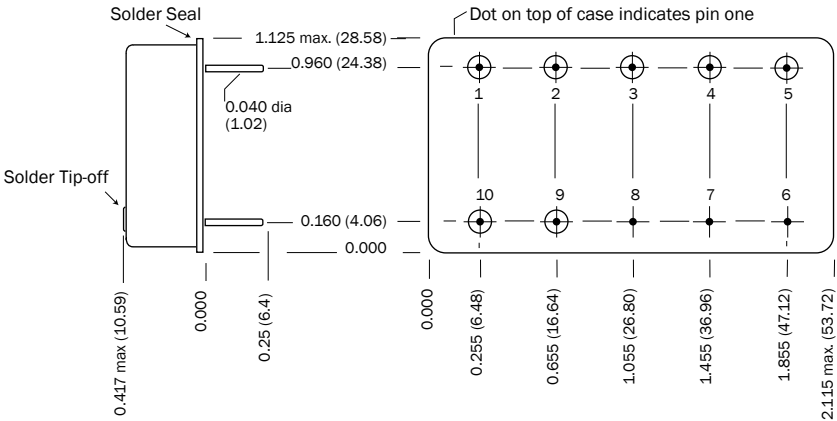

Weight 50 grams max.

Case dimensions in inches (mm)
Tolerance ±0.005 (0.13) for three decimal places
±0.01 (0.3) for two decimal places
unless otherwise specified

CAUTION
Heat from reflow or wave soldering may damage the device.
Solder pins individually with heat application not exceeding 300°C for 10 seconds per pin.

Materials
Header Cold Rolled Steel/Nickel/Tin
Cover Cold Rolled Steel/Nickel/Tin
Pins #52 alloy, compression glass seal
Tin plating .150 microinches minimum, included in pin diameter.
Seal hole 0.092 ±0.002 (2.34 ± 0.05)

Please refer to the numerical dimensions for accuracy.

FIGURE 34: CASE H4 - DUAL MODELS - NON 883

MTR (40) Single, Dual and Triple DC-DC Converters

16 TO 40 VOLT INPUT - 20-30 WATT

BOTTOM VIEW CASE J1

Flanged cases: Designator "F" required in Case Option position of model number.

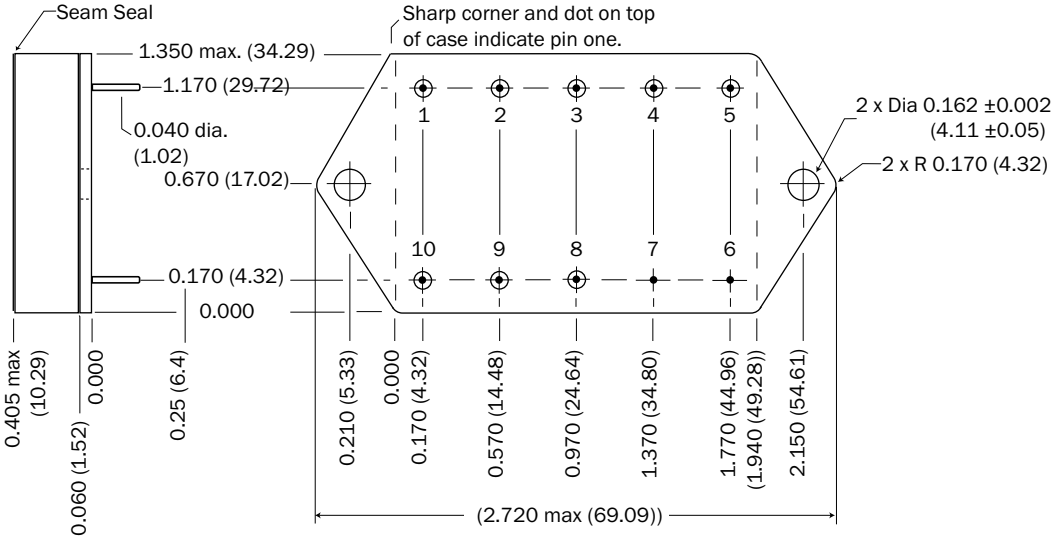

Weight: 62 grams maximum

Case dimensions in inches (mm)
Tolerance ± 0.005 (0.13) for three decimal places
 ± 0.01 (0.3) for two decimal places
unless otherwise specified

CAUTION
Heat from reflow or wave soldering may damage the device. Solder pins individually with heat application not exceeding 300°C for 10 seconds per pin.

Materials
Header Cold Rolled Steel/Nickel/Gold
Cover Kovar/Nickel
Pins #52 alloy/Gold ceramic seal
Gold plating of 50 - 150 microinches included in pin diameter
Seal Hole: 0.120 ± 0.002 (3.04 ± 0.05)

Please refer to the numerical dimensions for accuracy.

FIGURE 35: CASE J1 - TRIPLE MODELS

MTR (40) Single, Dual and Triple DC-DC Converters

16 TO 40 VOLT INPUT - 20-30 WATT

BOTTOM VIEW MTR SINGLE AND DUAL FLANGED

Flanged cases: Designator "F" required in Case Option position of model number.

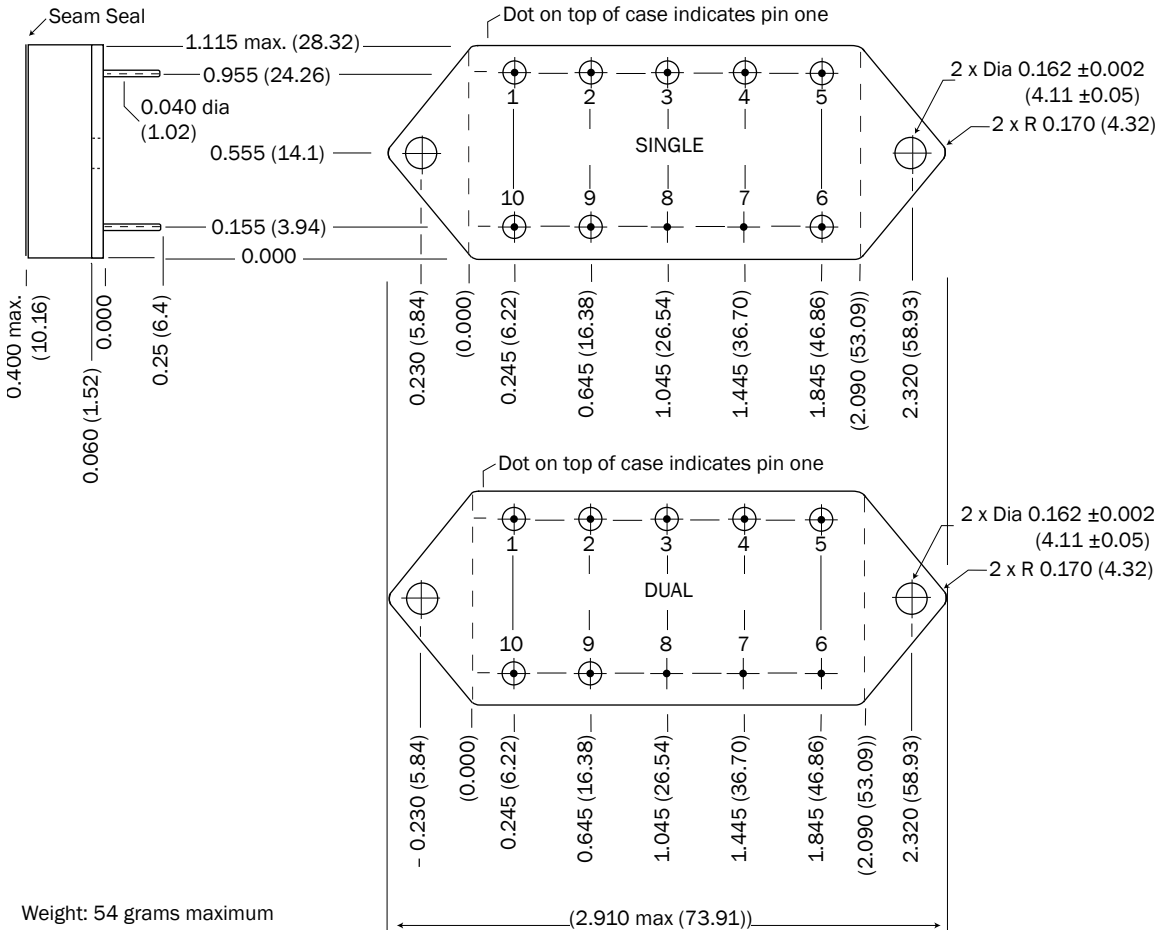

Case dimensions in inches (mm)
 Tolerance ±0.005 (0.13) for three decimal places
 ±0.01 (0.3) for two decimal places
 unless otherwise specified

CAUTION
 Heat from reflow or wave soldering may damage the device. Solder pins individually with heat application not exceeding 300°C for 10 seconds per pin.

Materials
 Header Cold Rolled Steel/Nickel/Gold
 Cover Kovar/Nickel
 Pins #52 alloy/Gold, ceramic seal.
 Gold plating of 50 - 150 microinches included in pin diameter
 Seal hole 0.120 ±0.002 (3.04 ±0.05)

Please refer to the numerical dimensions for accuracy.

FIGURE 36: CASE K3 – SINGLE AND DUAL 883 MODELS
 APPLIES TO ALL SINGLE MODELS, APPLIES ONLY TO 883 DUAL MODELS

MTR (40) Single, Dual and Triple DC-DC Converters

16 TO 40 VOLT INPUT - 20-30 WATT

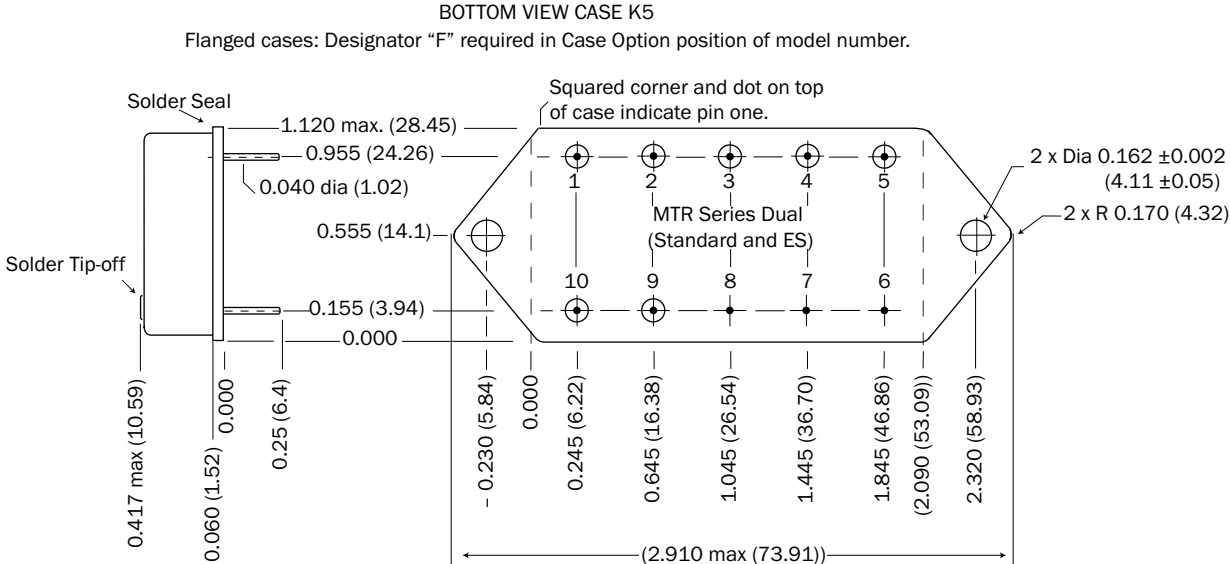

Weight: 54 grams max.

Case dimensions in inches (mm)
Tolerance ±0.005 (0.13) for three decimal places
±0.01 (0.3) for two decimal places
unless otherwise specified

CAUTION
Heat from reflow or wave soldering may damage the device.
Solder pins individually with heat application not exceeding 300°C for 10 seconds per pin.

Materials
Header Cold Rolled Steel/Nickel/Tin
Cover Cold Rolled Steel/Nickel/Tin
Pins #52 alloy, compression glass seal
Tin plating, 150 microinches minimum included in pin diameter.
Seal hole 0.092 ± 0.002 (2.34 ± 0.05)

Please refer to the numerical dimensions for accuracy.

FIGURE 37: CASE K5 - DUAL MODELS - NON 883

MTR (40) Single, Dual and Triple DC-DC Converters

16 TO 40 VOLT INPUT – 20-30 WATT

ELEMENT EVALUATION ¹ HIGH RELIABILITY DC-DC CONVERTERS AND EMI FILTERS /883 (CLASS H)

COMPONENT-LEVEL TEST PERFORMED	QML	
	CLASS H /883	
	M/S ²	P ³
Element Electrical	■	■
Visual	■	■
Internal Visual	■	
Final Electrical	■	■
Wire Bond Evaluation	■	■

- Notes
1. Element evaluation does not apply to standard and /ES product.
 2. M/S = Active components (microcircuit and semiconductor die).
 3. P = Passive components, Class H element evaluation. Not applicable to standard and /ES element evaluation.

TABLE 13: ELEMENT EVALUATION

MTR (40) Single, Dual and Triple DC-DC Converters

16 TO 40 VOLT INPUT – 20-30 WATT

ENVIRONMENTAL SCREENING HIGH RELIABILITY DC-DC CONVERTERS STANDARD, /ES AND /883 (CLASS H)

TEST PERFORMED	NON-QML ¹		CLASS H QML ²	
	STANDARD	/ES	/883 CH ³	/883 QML ⁴
Pre-cap Inspection, Method 2017, 2032	■	■	■	■
Temperature Cycle (10 times)				
Method 1010, Cond. C, -65°C to +150°C, ambient			■	■
Method 1010, Cond. B, -55°C to +125°C, ambient		■		
Constant Acceleration				
Method 2001, 3000 g			■	■
Method 2001, 500 g		■		
PIND, Test Method 2020, Cond. A			■ ⁵	■ ⁵
Burn-in Method 1015, +125°C case, typical ⁶				
96 hours		■		
160 hours			■	■
Final Electrical Test, MIL-PRF-38534, Group A,				
Subgroups 1 through 6, -55°C, +25°C, +125°C case			■	■
Subgroups 1 and 4, +25°C case	■	■		
Hermeticity Test, Method 1014				
Gross Leak, Cond. C ₁ , fluorocarbon		■	■	■
Fine Leak, Cond. A ₂ , helium		■	■	■
Gross Leak, Dip	■			
Final visual inspection, Method 2009	■	■	■	■

Test methods are referenced to MIL-STD-883 as determined by MIL-PRF-38534.

Notes

1. Non-QML products may not meet all of the requirements of MIL-PRF-38534.
2. All processes are QML qualified and performed by certified operators.
3. Class H QML products with no SMD number are marked "CH" per MIL-PRF-38534, 3.9.5.8.3, Table III.
4. Class H QML products have an SMD number
5. Not required by DLA but performed to assure product quality.
6. Burn-in temperature designed to bring the case temperature to +125°C minimum. Burn-in is a powered test.

TABLE 14: ENVIRONMENTAL SCREENING