

MSA+ Single and Dual DC-DC Converters

PRELIMINARY - 15 TO 50 VOLT INPUT – 6 WATT

FEATURES

- Trim function $\pm 10\%$, single and duals
- Small size, 1.13 in² (7.31 cm²)
- -55° to +125° C operation
- 15 to 50 volt input
- Low output ripple
- 80 volts for 1 second transient protection
- Magnetic isolation
- Fixed high frequency switching
- Inhibit function
- Indefinite short circuit protection
- Efficiency up to 78% typical
- Soft-start function limits inrush current during start-up

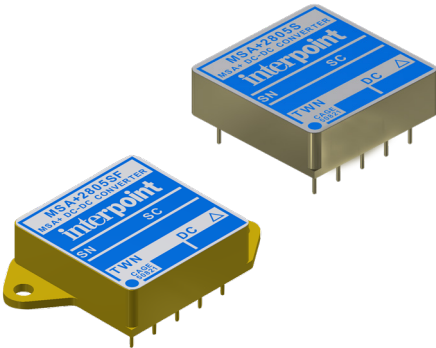

MODELS	
OUTPUT VOLTAGE (V)	
SINGLE	DUAL
3.3	± 5
5	± 6.3
6.3	± 12
12	± 15
15	

DESCRIPTION

The Interpoint® MSA+ Series™ of DC-DC converters offers up to 6 watts of power. The low profile MSA+ converters are manufactured in our fully certified and qualified MIL-PRF-38534 Class H production facility and packaged in hermetically sealed steel cases. Thick-film hybrid techniques provide military/aerospace reliability levels and optimum miniaturization. The hermetically sealed case is 1.065 by 1.065 inches with a height of 0.350 inches. Power density for the MSA+ Series converters is 15 watts per cubic inch.

CONVERTER DESIGN

The converters are switching regulators that use a flyback converter design with a constant switching frequency of 400 kHz typical. They are regulated, isolated units using a pulse width modulated topology and are built as high reliability thick-film hybrids. Isolation between input and output circuits is provided with a transformer in the forward power path and in the feedback control loop.

Excellent input line transient response and audio rejection is achieved by an advanced feed-forward compensation technique. For dual outputs, negative output regulation is maintained by tightly coupled magnetics. Up to 4.8 watts, 80% of the total output power, is available from either output, provided that the opposite output is simultaneously carrying 20% of the total power in order to maintain the specified regulation on the negative output.

A predictable current limit is accomplished by direct monitoring of the output load current, which results in a constant current output. Internal input and output filters eliminate the need for external capacitors for stable operation.

WIDE VOLTAGE RANGE

The MSA+ converters are designed to provide full power operation over a 15 to 50 volt input range.

TRIM FUNCTION

When trimming, ensure that neither the maximum current nor the maximum power is exceeded.

The MSA+ singles and duals can be trimmed $\pm 10\%$ using trim pin 4. However, the 3.3 single model's trim range is -5% and +10%. The dual outputs will then both be trimmed by the same percentage.

See Figure 1 and Figure 2 on page 2 for external trim resistor selection.

DYNAMIC RESPONSE

The feed-forward compensation system provides excellent dynamic response and audio rejection. Audio rejection is typically 50 dB.

SPAN VOLTAGE

Our duals can be configured as a single output where the positive output is used as one rail and the negative output is used as the other rail. As an example the positive and negative 15 volt dual can be configured as a single 30 volt output. If the dual is configured as a positive 30 volt output the negative output would be used as system ground and the positive output would be used as the positive 30 volt output. In all cases Output Common of the converter is not connected. The maximum capacitance when using a span voltage on a dual is half the value specified for each output.

SCREENING

The converters are offered with /883 (Class H), ES or standard screening. For screening options and descriptions see Table 10 on page 20.

MSA+ Single and Dual DC-DC Converters

PRELIMINARY - 15 TO 50 VOLT INPUT – 6 WATT

INHIBIT FUNCTION

The inhibit feature can be used to disable internal switching and inhibit the unit’s output. Inhibiting in this manner results in low standby current and no generation of switching noise.

The converter is inhibited when the inhibit pin is pulled below 0.8 volts and enabled when its inhibit pin is left floating. An external inhibit interface should be used to pull the converter’s inhibit pin below 0.8 volts while sinking the maximum inhibit current. It also allows the inhibit pin to float high to enable the converter. A voltage should not be applied to the inhibit pin. The open circuit output voltage associated with the inhibit pin is 9.5 to 11.5 volts. In the inhibit mode, a maximum of 4 mA is sourced from the inhibit pin. See Figure 4 and Figure 3 on page 3.

UNDERVOLTAGE LOCKOUT

Undervoltage lockout helps keep system current levels low during initialization or re-start operations. A low voltage lockout feature keeps the converter shutdown below approximately 12.7 volts to ensure smooth initialization.

TRANSIENT PROTECTION

The MSA+ can withstand short term transients of up to 80 volts for up to one second without damage.

MIL-STD-461

Use the FMCE-0328 filter to pass the CE03 requirements of MIL-STD-461C. Or and FMCE filter up to the rated current of the filter.

PACKAGING

The MSA+ Series converters are packaged in hermetically sealed, seam-sealed steel cases which provide EMI/RFI shielding. The small size, 1.065 x 1.065 x 0.350 inches (27.05 x 27.05 x 8.89 mm), saves space and weight in critical applications. They are available in non-flange or offset flange cases. See Figure 7 on page 19 and Figure 8 on page 18.

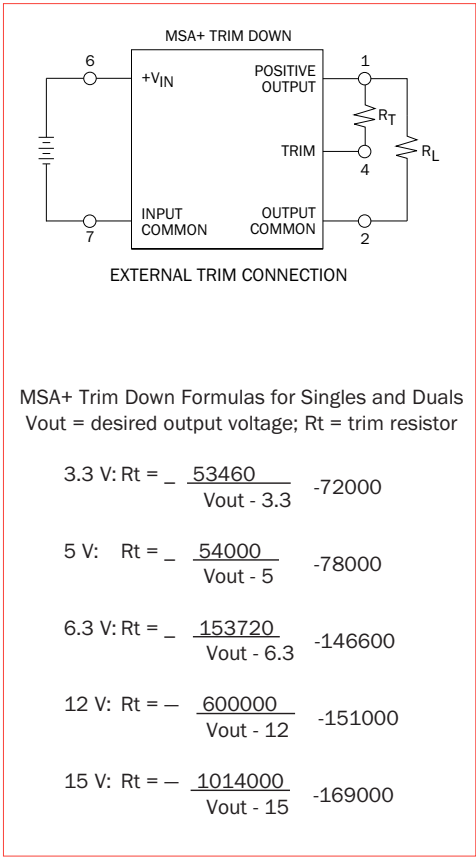

FIGURE 1: MSA+ TRIM DOWN

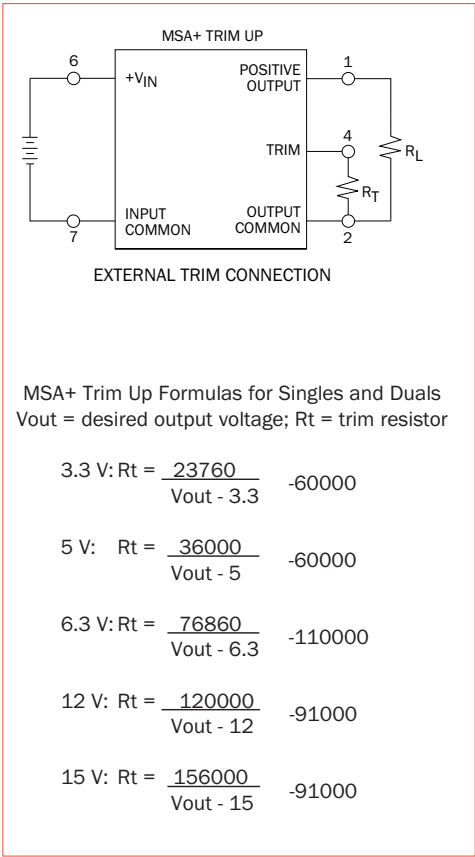

FIGURE 2: MSA+ TRIM UP

MSA+ Single and Dual DC-DC Converters

PRELIMINARY - 15 TO 50 VOLT INPUT - 6 WATT

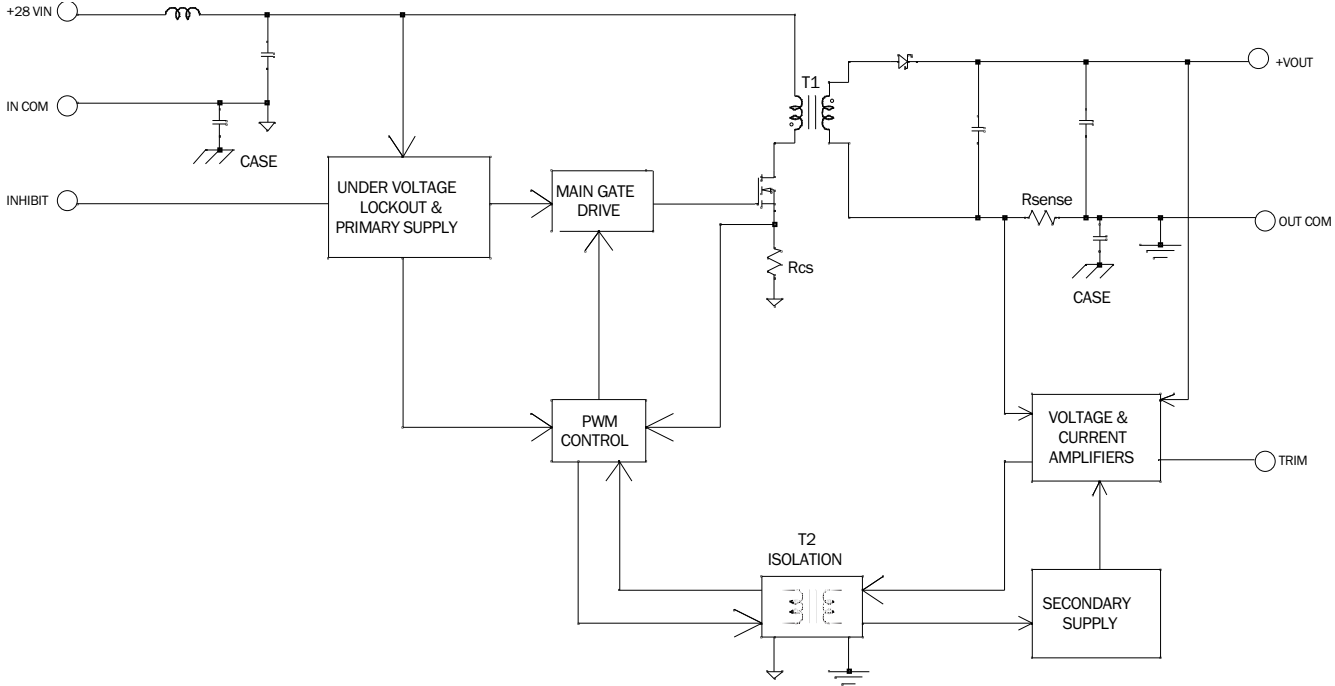

FIGURE 3: BLOCK DIAGRAM MSA+ SINGLE OUTPUT

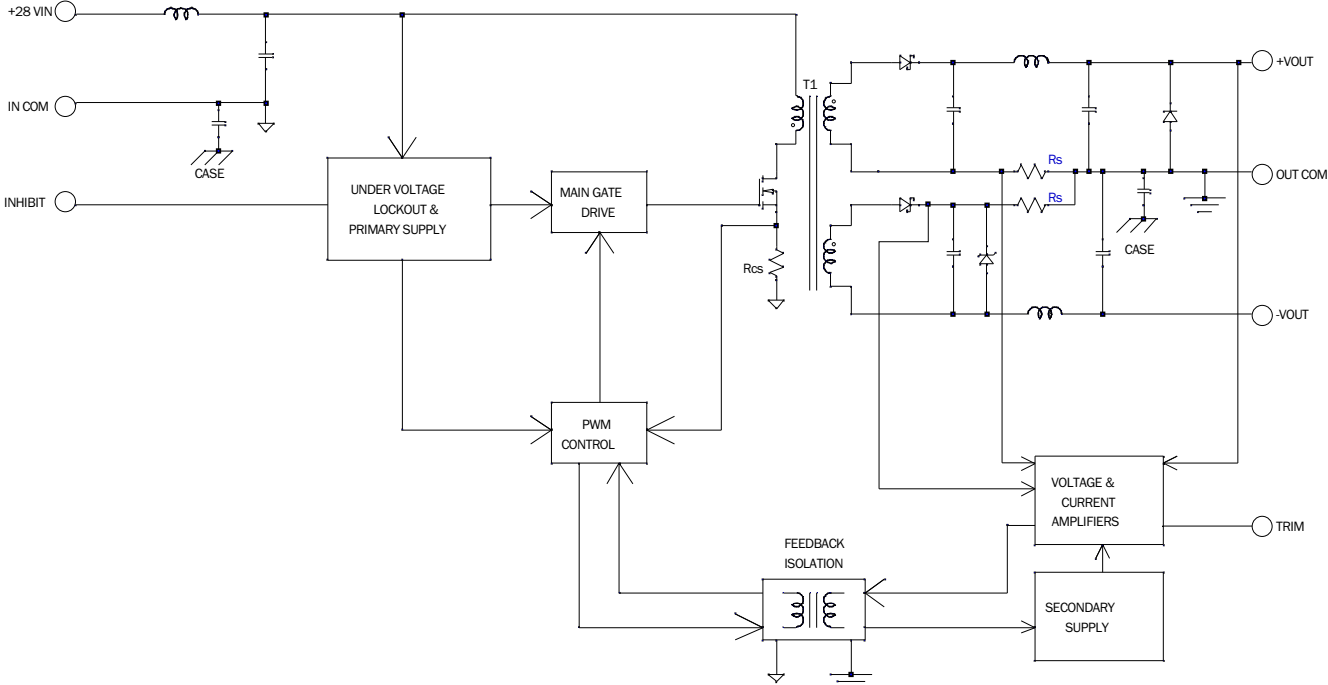

FIGURE 4: BLOCK DIAGRAM MSA+ DUAL OUTPUT

MSA+ Single and Dual DC-DC Converters

PRELIMINARY - 15 TO 50 VOLT INPUT – 6 WATT

PIN OUT		
Pin	Single Output	Dual Output
1	Positive Output	Positive Output
2	Output Common	Output Common
3	No Connection	Negative Output
4	Trim	Trim
5	Inhibit	Inhibit
6	Positive Input	Positive Input
7	Input Common	Input Common
8	Case Ground	Case Ground

TABLE 1: MSA+ PIN OUT

MSA+ PINS NOT IN USE	
Inhibit	Leave unconnected
“No Connection” pin	Leave unconnected
Trim	Leave unconnected

TABLE 2: MSA+ PINS NOT IN USE

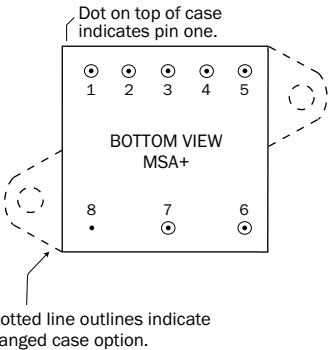

See Figure 7 on page 19 and Figure 8 on page 18.

FIGURE 5: MSA+ PIN OUT BOTTOM VIEW

MSA+ Single and Dual DC-DC Converters

PRELIMINARY - 15 TO 50 VOLT INPUT – 6 WATT

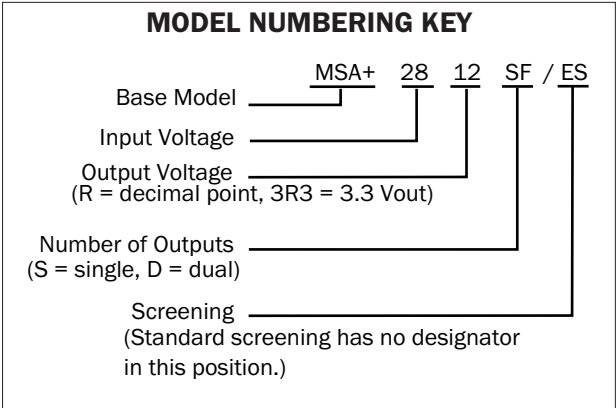

FIGURE 6: MSA+ MODEL NUMBERING KEY

SMD NUMBERS	
STANDARD MICROCIRCUIT DRAWING (SMD)	MSA+ SIMILAR PART
5962-0621003HMC IN PROCESS	MSA+283R3S/883
5962-9309205HMC IN PROCESS	MSA+2805S/883
5962-9309206HMC IN PROCESS	MSA+286R3S/883
5962-9309305HMC IN PROCESS	MSA+2812S/883
5962-9309404HMC IN PROCESS	MSA+2815S/883
5962-0052205HMC IN PROCESS	MSA+2805D/883
5962-0052206HMC IN PROCESS	MSA+286R3D/83
5962-9308904HMC IN PROCESS	MSA+2812D/883
5962-9309003HMC IN PROCESS	MSA+2815D/883

SMD numbers shown are for screening level Class H, standard MSA+ case (M), standard pin seal and non-solder dipped pins (C). For other options please refer to the SMD for the SMD number and the vendor similar number. All SMD numbers are listed on the SMD in the "Bulletin" which is the last page of the SMD. For exact specifications for an SMD product, refer to the SMD. SMDs can be downloaded from <https://landandmaritimeapps.dla.mil/programs/smcr>

TABLE 3: SMD NUMBER CROSS REFERENCE

MODEL NUMBER OPTIONS ¹					
TO DETERMINE THE MODEL NUMBER ENTER ONE OPTION FROM EACH CATEGORY IN THE FORM BELOW.					
CATEGORY	Base Model and Input Voltage	Output Voltage ²	Number of Outputs ³	Case Options ⁴	Screening ⁵
OPTIONS	MSA+28	3R3, 05, 6R3, 12, 15	S	(non-flanged, leave blank)	(standard, leave blank)
		05, 6R3, 12, 15	D	F (flanged)	ES /SX ⁶ /883
FILL IN FOR MODEL # ⁷	_MSA+28_	_____	_____	_____	/ _____

Notes

- See Figure 6 above for an example of a model number.
- Output Voltage: An R indicates a decimal point. 3R3 is 3.3 volts out. The values of 3.3 is only available in single output models.
- Number of Outputs: S is a single output and D is a dual output.
- Case Options: For the standard case (Figure 7 on page 19) leave the Case Option blank. For the flanged case option (Figure 8 on page 18), insert the letter F in the Case Option position.
- Screening: For standard screening leave the screening option blank. For other screening options, insert the desired screening level. For more information see Table 10 on page 20.
- "SX" screening performed per MIL-PRF-38534, MIL-STD-883 for Class H but the product is not yet QML. See Table 10 on page 20.
- If ordering by model number add suffix "-Q" to request solder dipped leads (MSA+2805S/ES-Q).

TABLE 4: MODEL NUMBER OPTIONS

MSA+ Single and Dual DC-DC Converters

PRELIMINARY - 15 TO 50 VOLT INPUT – 6 WATT

TABLE 5: OPERATING CONDITIONS - ALL MODELS, 25 °C CASE, 28 VIN, UNLESS OTHERWISE SPECIFIED.

PARAMETER	CONDITIONS	ALL MODELS			UNIT
		MIN	TYP	MAX	
LEAD SOLDERING TEMPERATURE	10 SECONDS MAX. PER LEAD	–	–	300	°C
STORAGE TEMPERATURE ¹		-65	–	+150	°C
CASE OPERATING TEMPERATURE	FULL POWER	-55	–	+125	°C
	ABSOLUTE ¹	-55	–	+135	
DERATING OUTPUT POWER/CURRENT ¹	LINEARLY	From 100% at 125 °C to 0% at 135 °C			
ISOLATION: INPUT TO OUTPUT, INPUT TO CASE, OUTPUT TO CASE ²	@ 500 VDC AT 25 °C	100	–	–	Megohms
INPUT TO OUTPUT CAPACITANCE ¹		–	50	–	pF
UNDERVOLTAGE LOCKOUT ¹		–	13	–	V
CURRENT LIMIT ^{1, 3}	% OF FULL LOAD	–	130	–	%
AUDIO REJECTION ¹		–	50	–	dB
SWITCHING FREQUENCY	-55 ° TO +125 °C	350	–	450	kHz
INHIBIT ACTIVE LOW (OUTPUT DISABLED) Do not apply a voltage to the inhibit pin. ⁴	INHIBIT PIN PULLED LOW	–	–	0.8	V
	INHIBIT PIN SOURCE CURRENT ¹	–	–	4	mA
	REFERENCED TO	INPUT COMMON			
INHIBIT ACTIVE HIGH (OUTPUT ENABLED)	INHIBIT PIN CONDITION	OPEN COLLECTOR OR UNCONNECTED			
	OPEN PIN VOLTAGE ¹	9.5	–	11.5	V

Notes

- Guaranteed by qualification test and/or analysis. Not a production test.
- When testing isolation, input pins are tied together and output pins are tied together. They are tested against each other and against case. Discharge the pins before and after testing.
- Current limit is defined as the point at which the output voltage decreases by 1%.
Dual outputs: The over-current limit will trigger when the sum of the currents from both outputs reaches 130% (typical value) of the maximum rated "total" current of both outputs.
- An external inhibit interface should be used to pull the inhibit low or leave it floating. The inhibit pin can be left unconnected if not used.

MSA+ Single and Dual DC-DC Converters

PRELIMINARY - 15 TO 50 VOLT INPUT - 6 WATT

TABLE 6: ELECTRICAL CHARACTERISTICS -55°C TO +125°C CASE, 28 VIN, 100% LOAD, UNLESS OTHERWISE SPECIFIED.

MSA+ SINGLE OUTPUT MODELS		MSA+283R3S			MSA+2805S			MSA+286R3S			UNITS
PARAMETER	CONDITIONS	MIN	TYP	MAX	MIN	TYP	MAX	MIN	TYP	MAX	
OUTPUT VOLTAGE		3.15	3.30	3.45	4.80	5.00	5.20	6.10	6.30	6.50	V
OUTPUT CURRENT	V _{IN} = 15 TO 50	0	—	1500	0	—	1200	0	—	950	mA
OUTPUT POWER	V _{IN} = 15 TO 50	0	—	5	0	—	6	0	—	6	W
OUTPUT RIPPLE	T _C = 25°C	—	20	30	—	20	30	—	20	30	mV p-p
10 kHz - 10 MHz	T _C = -55°C TO +125°C	—	30	40	—	30	40	—	30	40	
LINE REGULATION	V _{IN} = 15 TO 50	—	10	50	—	10	50	—	10	50	mV
LOAD REGULATION	NO LOAD TO FULL	—	10	50	—	10	50	—	10	50	mV
INPUT VOLTAGE	CONTINUOUS	15	28	50	15	28	50	15	28	50	V
NO LOAD TO FULL	TRANSIENT 1 SEC ¹	—	—	80	—	—	80	—	—	80	
INPUT CURRENT	NO LOAD	—	27	40	—	27	40	—	28	40	mA
	INHIBITED	—	3	6	—	3	6	—	3	6	
INPUT RIPPLE CURRENT	10 kHz - 10 MHz	—	95	150	—	95	150	—	95	150	mA p-p
EFFICIENCY	T _C = 25°C	66	70	—	69	73	—	68	73	—	%
	T _C = -55°C TO +125°C	64	—	—	67	72	—	67	72	—	
LOAD FAULT ^{2,3}	POWER DISSIPATION	—	—	2.5	—	—	2.5	—	—	2.5	W
SHORT CIRCUIT	RECOVERY ¹	—	—	30	—	—	30	—	—	30	ms
STEP LOAD RESPONSE ^{3,4}	TRANSIENT	—	—	±500	—	—	±500	—	—	±550	mV pk
50% - 100% - 50%	RECOVERY	—	—	1200	—	—	1200	—	—	1200	
STEP LINE RESPONSE ^{1,3,5}	TRANSIENT	—	—	±500	—	—	±600	—	—	±700	mV pk
V _{IN} = 16 - 40 - 16	RECOVERY	—	—	1500	—	—	1500	—	—	1500	
STEP LINE RESPONSE ^{1,3,5}	TRANSIENT	—	±350	—	—	±350	—	—	±350	—	mV pk
V _{IN} = 15 - 50 - 15	RECOVERY	—	1200	—	—	1200	—	—	1200	—	
START-UP ³	DELAY	—	—	30	—	—	30	—	—	30	ms
V _{IN} = 0 - 28	OVERSHOOT ¹	—	—	200	—	—	200	—	—	200	mV pk
CAPACITIVE LOAD ^{1,6}	T _C = 25°	—	—	500	—	—	500	—	—	500	µF

Notes

- Guaranteed by characterization test and/or analysis. Not a production test.
- Indefinite short circuit protection not guaranteed above 125°C (case).
- Recovery time is measured from application of the transient to point at which V_{out} is within 1% of V_{out} at final value.
- Step load test is performed at 10 microseconds typical.
- Step line test is performed at 100 microseconds ± 20 microseconds.
- No effect on dc performance.

MSA+ Single and Dual DC-DC Converters

PRELIMINARY - 15 TO 50 VOLT INPUT - 6 WATT

TABLE 7: ELECTRICAL CHARACTERISTICS -55°C TO +125°C CASE, 28 VIN, 100% LOAD, UNLESS OTHERWISE SPECIFIED.

MSA+ SINGLE OUTPUT MODELS		MSA+2812S			MSA+2815S			UNITS
PARAMETER	CONDITIONS	MIN	TYP	MAX	MIN	TYP	MAX	
OUTPUT VOLTAGE		11.52	12.00	12.48	14.40	15.00	15.60	V
OUTPUT CURRENT	$V_{IN} = 15$ TO 50	0	—	500	0	—	400	mA
OUTPUT POWER	$V_{IN} = 15$ TO 50	0	—	6	0	—	6	W
OUTPUT RIPPLE 10 kHz - 10 MHz	$T_C = 25^\circ\text{C}$	—	20	30	—	20	30	mV p-p
	$T_C = -55^\circ\text{C}$ TO $+125^\circ\text{C}$	—	30	40	—	30	40	
LINE REGULATION	$V_{IN} = 15$ TO 50	—	10	50	—	10	50	mV
LOAD REGULATION	NO LOAD TO FULL	—	10	50	—	10	50	mV
INPUT VOLTAGE NO LOAD TO FULL	CONTINUOUS	15	28	50	15	28	50	V
	TRANSIENT 1 SEC ¹	—	—	80	—	—	80	
INPUT CURRENT	NO LOAD	—	29	42	—	31	44	mA
	INHIBITED	—	3	6	—	3	6	
INPUT RIPPLE CURRENT	10 kHz - 10 MHz	—	70	150	—	70	150	mA p-p
EFFICIENCY	$T_C = 25^\circ\text{C}$	70	76	—	73	78	—	%
	$T_C = -55^\circ\text{C}$ TO $+125^\circ\text{C}$	68	—	—	72	77	—	
LOAD FAULT ^{2, 3}	POWER DISSIPATION	—	—	2.5	—	—	2.5	W
SHORT CIRCUIT	RECOVERY ¹	—	—	30	—	—	30	ms
STEP LOAD RESPONSE ^{3, 4} 50% - 100% - 50%	TRANSIENT	—	—	±750	—	—	±750	mV pk
	RECOVERY	—	—	1200	—	—	1200	
STEP LINE RESPONSE ^{1, 3, 5} $V_{IN} = 16 - 40 - 16$	TRANSIENT	—	—	±750	—	—	±750	mV pk
	RECOVERY	—	—	1500	—	—	1500	
STEP LINE RESPONSE ^{1, 3, 5} $V_{IN} = 15 - 50 - 15$	TRANSIENT	—	±350	—	—	±350	—	mV pk
	RECOVERY	—	1200	—	—	1200	—	
START-UP ³ $V_{IN} = 0 - 28$	DELAY	—	—	30	—	—	30	ms
	OVERSHOOT ¹	—	—	200	—	—	200	
CAPACITIVE LOAD ¹	$T_C = 25^\circ$	—	—	500	—	—	500	μF

Notes

- Guaranteed by characterization test and/or analysis. Not a production test.
- Indefinite short circuit protection not guaranteed above 125°C (case).
- Recovery time is measured from application of the transient to point at which V_{out} is within 1% of V_{out} at final value.
- Step load test is performed at 10 microseconds typical.
- Step line test is performed at 100 microseconds ± 20 microseconds.
- No effect on dc performance.

MSA+ Single and Dual DC-DC Converters

PRELIMINARY - 15 TO 50 VOLT INPUT - 6 WATT

TABLE 8: ELECTRICAL CHARACTERISTICS -55 °C TO +125 °C CASE, 28 VIN, 100% LOAD, UNLESS OTHERWISE SPECIFIED.

MSA+ DUAL OUTPUT MODELS		MSA+2805D			MSA+286R3D			UNITS
PARAMETER	CONDITIONS	MIN	TYP	MAX	MIN	TYP	MAX	
OUTPUT VOLTAGE	+V _{OUT}	4.80	5.00	5.20	6.10	6.30	6.50	V
	-V _{OUT}	4.75	5.00	5.25	6.05	6.30	6.55	
OUTPUT CURRENT ² V _{IN} = 15 TO 50	EITHER OUTPUT	—	±600	960	—	±475	760	mA
	TOTAL OUTPUT	—	—	1200	—	—	950	
OUTPUT POWER ² V _{IN} = 15 TO 50	EITHER OUTPUT	—	±3	4.8	—	±3	4.8	W
	TOTAL OUTPUT	—	—	6	—	—	6	
OUTPUT RIPPLE, ± V _{OUT} 10 kHz - 10 MHz	T _C = 25 °C	—	30	60	—	30	60	mV p-p
	T _C = -55 °C TO +125 °C	—	40	70	—	40	70	
LINE REGULATION V _{IN} = 15 TO 50	+V _{OUT}	—	10	25	—	10	50	mV
	-V _{OUT}	—	40	75	—	40	150	
LOAD REGULATION NO LOAD TO FULL	+V _{OUT}	—	10	50	—	—	75	mV
	-V _{OUT}	—	115	200	—	50	200	
CROSS REGULATION ^{1, 3} EFFECT ON -V _{OUT}	20 TO 80%	—	10	—	—	10	—	%
	50 TO 20%	—	5	8	—	5	8	
INPUT VOLTAGE NO LOAD TO FULL	CONTINUOUS	15	28	50	15	28	50	V
	TRANSIENT 1 SEC ¹	—	—	80	—	—	80	
INPUT CURRENT	NO LOAD	—	30	35	—	30	40	mA
	INHIBITED	—	3	6	—	3	6	
INPUT RIPPLE CURRENT	10 kHz - 10 MHz	—	90	160	—	90	160	mA p-p
EFFICIENCY	T _C = 25 °C	68	72	—	69	75	—	%
	T _C = -55 °C TO +125 °C	65	—	—	67	—	—	
LOAD FAULT ^{4, 5} SHORT CIRCUIT	POWER DISSIPATION	—	—	2.0	—	—	2.0	W
	RECOVERY ¹	—	—	30	—	—	30	ms
STEP LOAD RESPONSE ^{5, 6} 50% - 100% - 50%	TRANSIENT	—	—	±500	—	—	±600	mV pk
	RECOVERY	—	—	1000	—	—	1000	µs
STEP LINE RESPONSE ^{1, 4, 7} V _{IN} = 16 - 40 - 16	TRANSIENT	—	—	±600	—	—	±750	mV pk
	RECOVERY	—	—	1500	—	—	1500	µs
STEP LINE RESPONSE ^{1, 4, 7} V _{IN} = 15 - 50 - 15	TRANSIENT	—	±350	—	—	±350	—	mV pk
	RECOVERY	—	1200	—	—	1200	—	µs
START-UP ⁵ V _{IN} = 0 - 28	DELAY	—	—	30	—	—	30	ms
	OVERSHOOT ¹	—	—	200	—	—	200	mV pk
CAPACITIVE LOAD ^{1, 8, 9}	T _C = 25 °C	—	—	500	—	—	500	µF

Notes

- Guaranteed by characterization test and/or analysis. Not a production test.
- Up to 4.8 watts (80% of full power) is available from either output providing the opposite output is carrying 20% of total power.
- Shows regulation effect on the minus output during defined cross loading conditions.
- Indefinite short circuit protection not guaranteed above 125 °C (case).
- Recovery time is measured from application of the transient to point at which V_{out} is within 1% of V_{out} at final value.
- Step load test is performed at 10 microseconds typical.
- Step line test is performed at 100 microseconds ± 20 microseconds.
- Each output.
- No effect on dc performance.

MSA+ Single and Dual DC-DC Converters

PRELIMINARY - 15 TO 50 VOLT INPUT - 6 WATT

TABLE 9: ELECTRICAL CHARACTERISTICS -55 °C TO +125 °C CASE, 28 VIN, 100% LOAD, UNLESS OTHERWISE SPECIFIED.

MSA+ DUAL OUTPUT MODELS		MSA+2812D			MSA+2815D			UNITS
PARAMETER	CONDITIONS	MIN	TYP	MAX	MIN	TYP	MAX	
OUTPUT VOLTAGE	+V _{OUT}	11.52	12.00	12.48	14.40	15.00	15.60	V
	-V _{OUT}	11.04	12.00	12.96	13.80	15.00	16.20	
OUTPUT CURRENT ² V _{IN} = 15 TO 50	EITHER OUTPUT	—	±250	400	—	±200	320	mA
	TOTAL OUTPUT	—	—	500	—	—	400	
OUTPUT POWER ² V _{IN} = 15 TO 50	EITHER OUTPUT	—	±3	4.8	—	±3	4.8	W
	TOTAL OUTPUT	—	—	6	—	—	6	
OUTPUT RIPPLE, ± V _{OUT} 10 kHz - 10 MHz	T _C = 25 °C	—	20	40	—	20	40	mV p-p
	T _C = -55 °C TO +125 °C	—	30	50	—	30	50	
LINE REGULATION V _{IN} = 15 TO 50	+V _{OUT}	—	10	50	—	10	50	mV
	-V _{OUT}	—	—	50	—	—	50	
LOAD REGULATION NO LOAD TO FULL	+V _{OUT}	—	10	50	—	10	50	mV
	-V _{OUT}	—	90	200	—	—	200	
CROSS REGULATION ^{1, 3} EFFECT ON -V _{OUT}	20 TO 80%	—	—	—	—	—	—	%
	50 TO 20%	—	3.7	6	—	3	6	
INPUT VOLTAGE	CONTINUOUS	15	28	50	15	28	50	V
	TRANSIENT 1 SEC ¹	—	—	80	—	—	80	
INPUT CURRENT	NO LOAD	—	25	40	—	30	55	mA
	INHIBITED	—	3	6	—	3	6	
INPUT RIPPLE CURRENT 10 kHz - 10 MHz		—	70	150	—	70	150	mA p-p
EFFICIENCY	T _C = 25 °C	74	—	—	73	—	—	%
	T _C = -55 °C TO +125 °C	74	—	—	72	—	—	
LOAD FAULT ^{4, 5}	POWER DISSIPATION	—	—	2.0	—	—	2.0	W
SHORT CIRCUIT	RECOVERY ¹	—	—	30	—	—	30	ms
STEP LOAD RESPONSE ^{5, 6} 50% - 100% - 50%	TRANSIENT	—	—	±450	—	—	±550	mV pk
	RECOVERY	—	—	2000	—	—	2000	µs
STEP LINE RESPONSE ^{1, 4, 7} V _{IN} = 16 - 40 - 16	TRANSIENT	—	—	±1300	—	—	±1500	mV pk
	RECOVERY	—	—	2000	—	—	1200	µs
STEP LINE RESPONSE ^{1, 4, 7} V _{IN} = 15 - 50 - 15	TRANSIENT	—	±350	—	—	±350	—	mV pk
	RECOVERY	—	1200	—	—	1200	—	µs
START-UP ⁵ V _{IN} = 0 - 28	DELAY	—	—	30	—	—	30	ms
	OVERSHOOT ¹	—	—	200	—	—	200	mV pk
CAPACITIVE LOAD ^{1, 8, 9}	T _C = 25 °C	—	—	500	—	—	500	µF

Notes

- Guaranteed by characterization test and/or analysis. Not a production test.
- Up to 4.8 watts (80% of full power) is available from either output providing the opposite output is carrying 20% of total power.
- Shows regulation effect on the minus output during defined cross loading conditions.
- Indefinite short circuit protection not guaranteed above 125 °C (case).
- Recovery time is measured from application of the transient to point at which V_{out} is within 1% of V_{out} at final value.
- Step load test is performed at 10 microseconds typical.
- Step line test is performed at 100 microseconds ± 20 microseconds.
- Each output.
- No effect on dc performance.

MSA+ Single and Dual DC-DC Converters

PRELIMINARY - 15 TO 50 VOLT INPUT - 6 WATT

TYPICAL PERFORMANCE PLOTS: 25 °C CASE, 28 VIN, 100% LOAD, UNLESS OTHERWISE SPECIFIED.
FOR REFERENCE ONLY, NOT GUARANTEED SPECIFICATIONS.

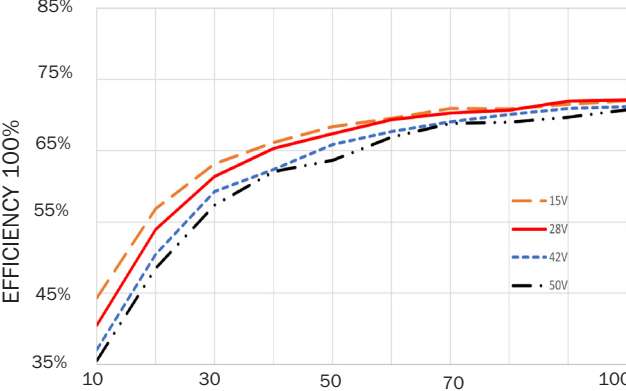

OUTPUT POWER
MSA+28R3RS EFFICIENCY
FIGURE 7

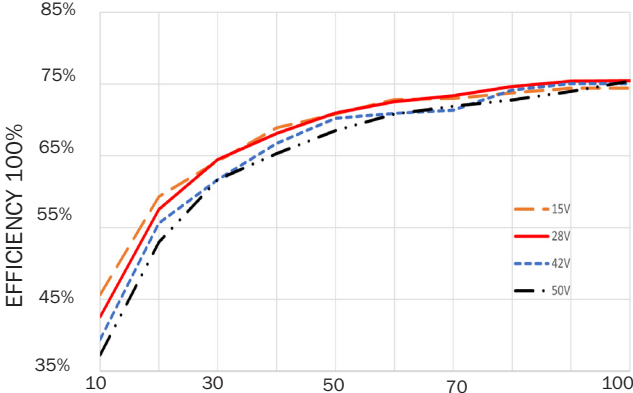

OUTPUT POWER
MSA+286R3S EFFICIENCY
FIGURE 9

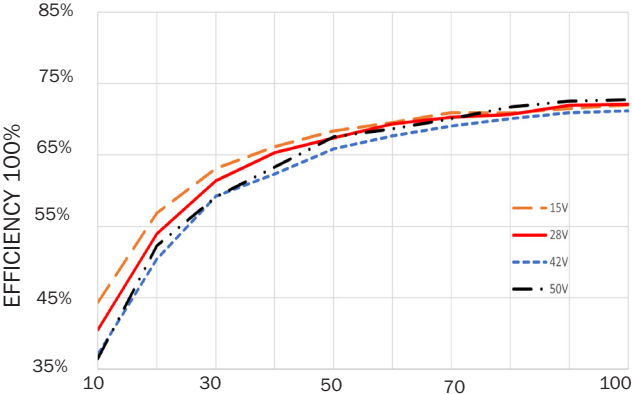

OUTPUT POWER
MSA+2805S EFFICIENCY
FIGURE 8

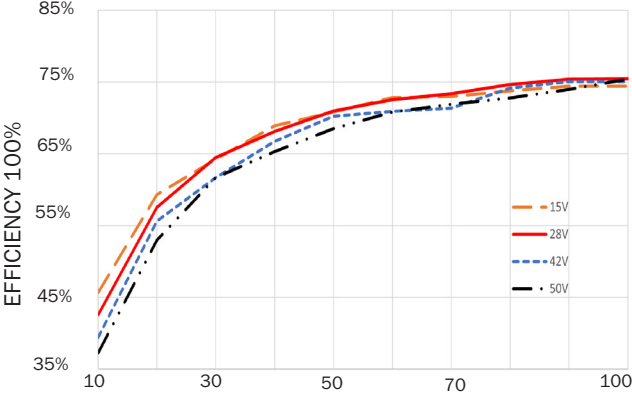

OUTPUT POWER
MSA+2812S EFFICIENCY
FIGURE 10

MSA+ Single and Dual DC-DC Converters

PRELIMINARY - 15 TO 50 VOLT INPUT - 6 WATT

TYPICAL PERFORMANCE PLOTS: 25 °C CASE, 28 VIN, 100% LOAD, UNLESS OTHERWISE SPECIFIED.
FOR REFERENCE ONLY, NOT GUARANTEED SPECIFICATIONS.

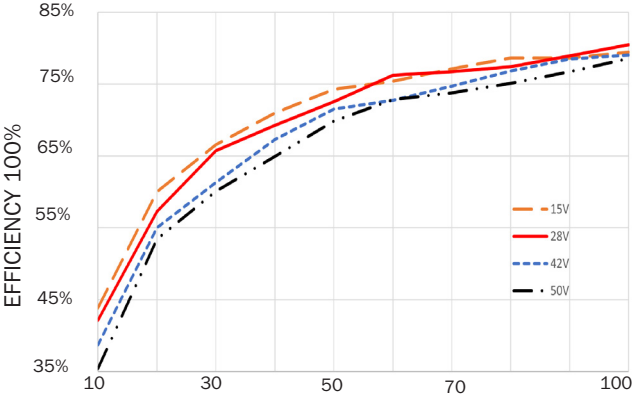

OUTPUT POWER
MSA+2815S EFFICIENCY
FIGURE 11

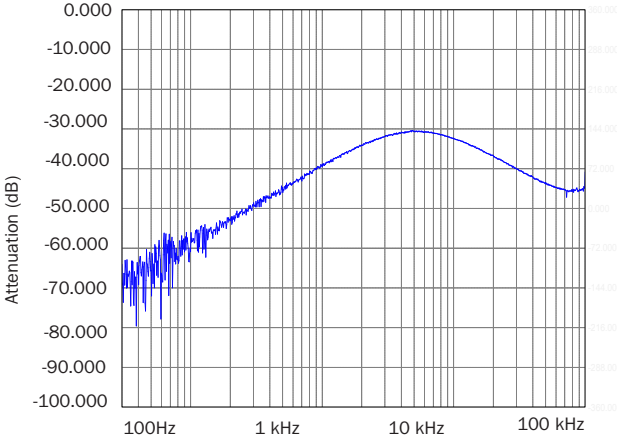

MSA+2805S SINGLE AUDIO REJECTION
FIGURE 12

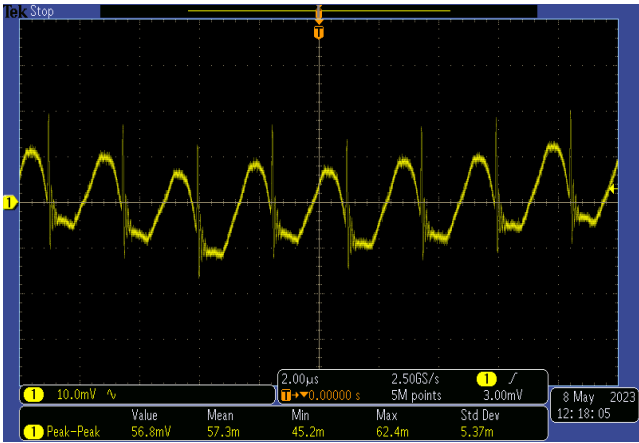

UNITS ARE PER DIVISION
MSA+2805S OUTPUT RIPPLE
FIGURE 13

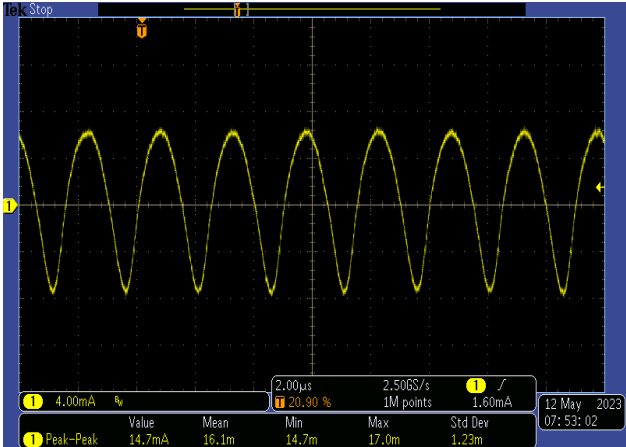

UNITS ARE PER DIVISION
MSA+2805S INPUT RIPPLE
FIGURE 14

MSA+ Single and Dual DC-DC Converters

PRELIMINARY - 15 TO 50 VOLT INPUT - 6 WATT

TYPICAL PERFORMANCE PLOTS: 25 °C CASE, 28 VIN, 100% LOAD, UNLESS OTHERWISE SPECIFIED.
FOR REFERENCE ONLY, NOT GUARANTEED SPECIFICATIONS.

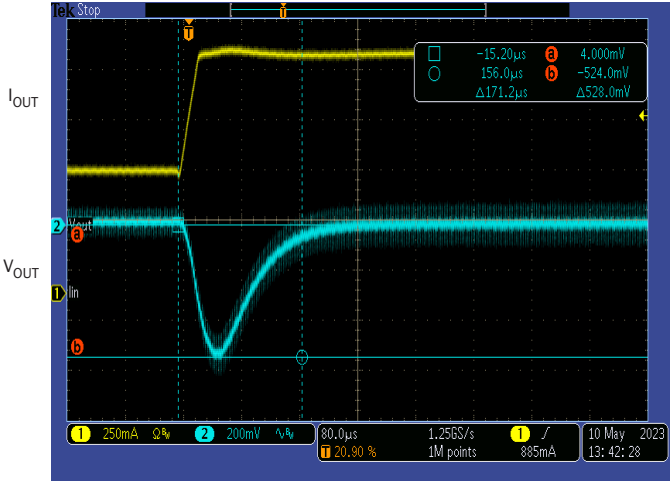

UNITS ARE PER DIVISION
MSA+2805S STEP LOAD 50% - 100%

FIGURE 15

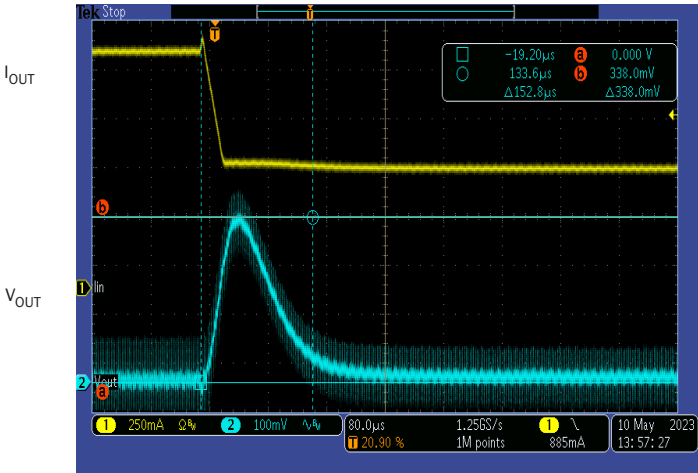

UNITS ARE PER DIVISION
MSA+2805S STEP LOAD 100% - 50%

FIGURE 16

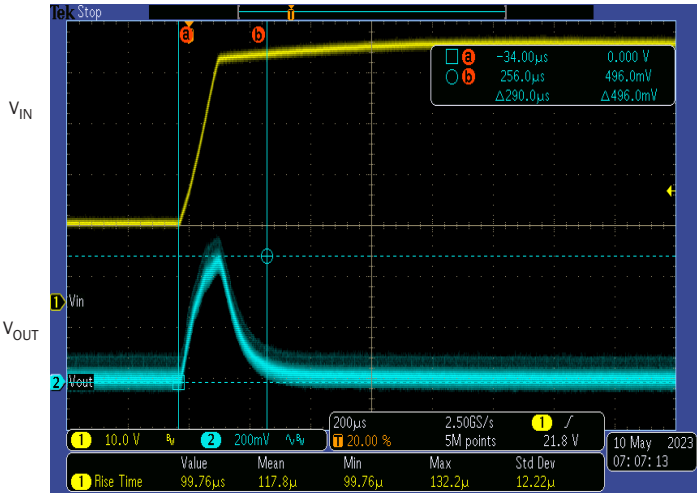

UNITS ARE PER DIVISION
MSA+2805S STEP LINE 15 - 50 VOLTS FULL LOAD

FIGURE 17

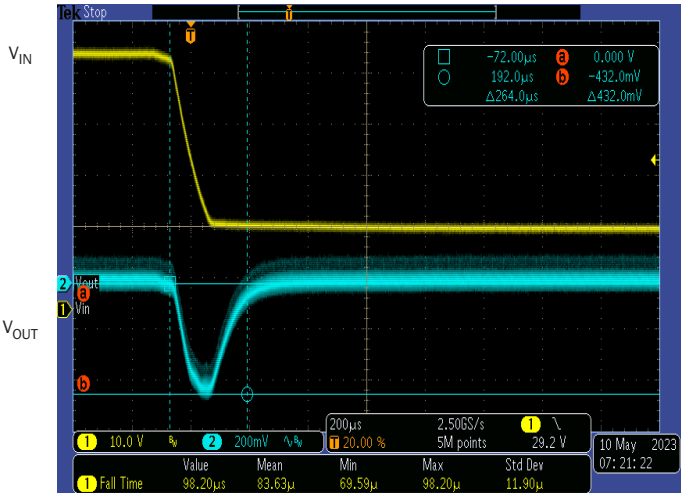

UNITS ARE PER DIVISION
MSA+2805S STEP LINE 50 - 15 VOLTS FULL LOAD

FIGURE 18

MSA+ Single and Dual DC-DC Converters

PRELIMINARY - 15 TO 50 VOLT INPUT - 6 WATT

TYPICAL PERFORMANCE PLOTS: 25 °C CASE, 28 VIN, 100% LOAD, UNLESS OTHERWISE SPECIFIED.
FOR REFERENCE ONLY, NOT GUARANTEED SPECIFICATIONS.



UNITS ARE PER DIVISION

MSA+2805S START-UP RESPONSE FULL LOAD
FIGURE 19

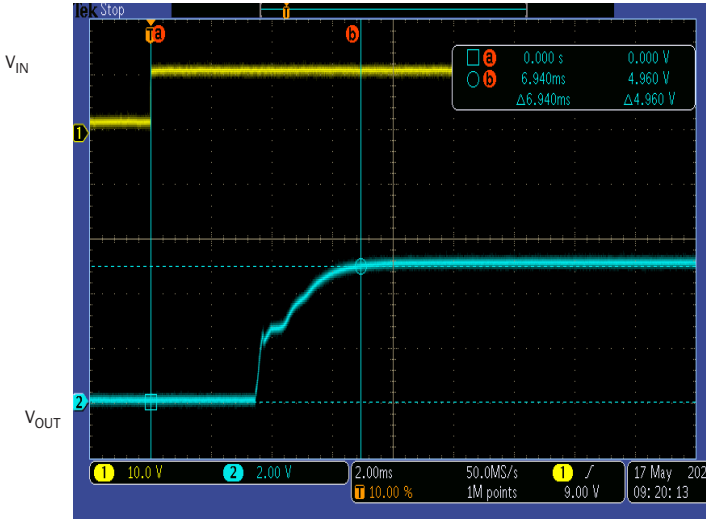

UNITS ARE PER DIVISION

MSA+2805S START-UP RESPONSE FULL LOAD W 500uF CAP
FIGURE 20

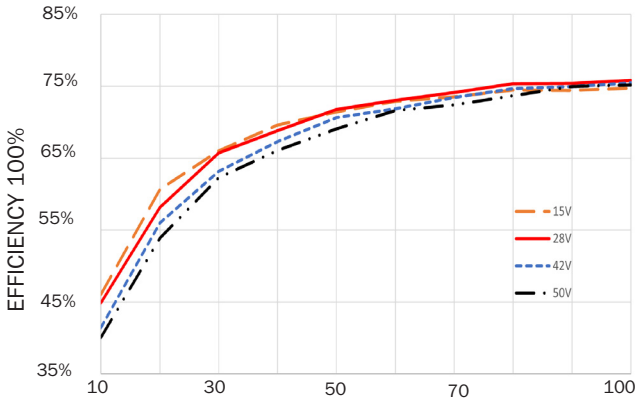

OUTPUT POWER
MSA+2805D EFFICIENCY
FIGURE 21

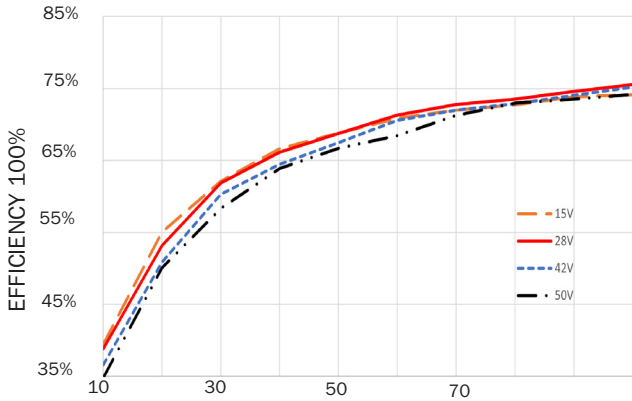

OUTPUT POWER
MSA+286R3D EFFICIENCY
FIGURE 22

MSA+ Single and Dual DC-DC Converters

PRELIMINARY - 15 TO 50 VOLT INPUT - 6 WATT

TYPICAL PERFORMANCE PLOTS: 25 °C CASE, 28 VIN, 100% LOAD, UNLESS OTHERWISE SPECIFIED.
FOR REFERENCE ONLY, NOT GUARANTEED SPECIFICATIONS.

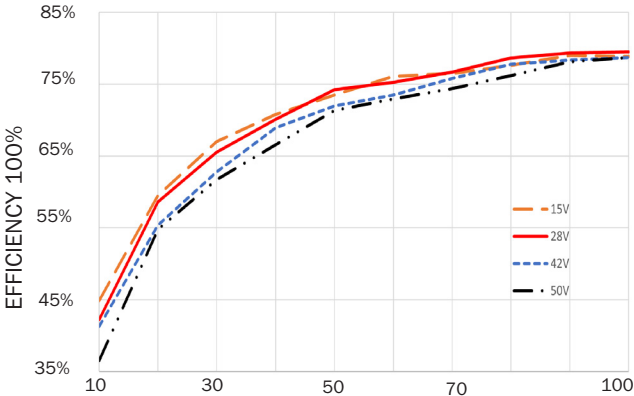

OUTPUT POWER
MSA+2812D EFFICIENCY
FIGURE 23

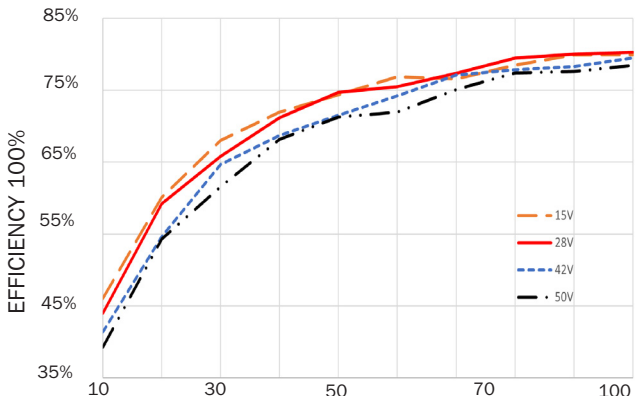

OUTPUT POWER
MSA+2815D EFFICIENCY
FIGURE 24

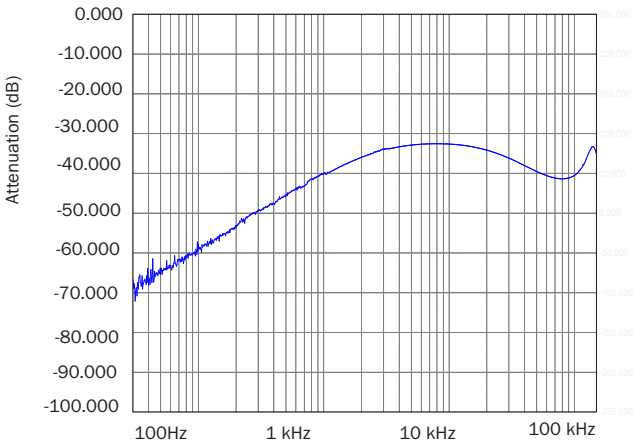

Frequency (Hz)
MSA+2805D AUDIO REJECTION
FIGURE 25

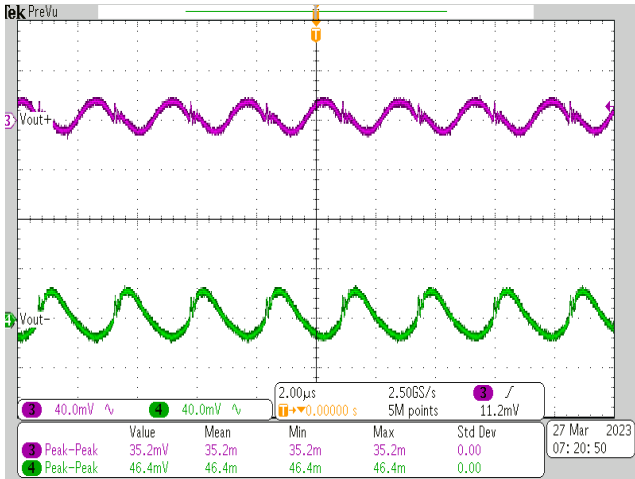

UNITS ARE PER DIVISION
MSA+2805D OUTPUT RIPPLE
FIGURE 26

MSA+ Single and Dual DC-DC Converters

PRELIMINARY - 15 TO 50 VOLT INPUT - 6 WATT

TYPICAL PERFORMANCE PLOTS: 25 °C CASE, 28 VIN, 100% LOAD, UNLESS OTHERWISE SPECIFIED.
FOR REFERENCE ONLY, NOT GUARANTEED SPECIFICATIONS.

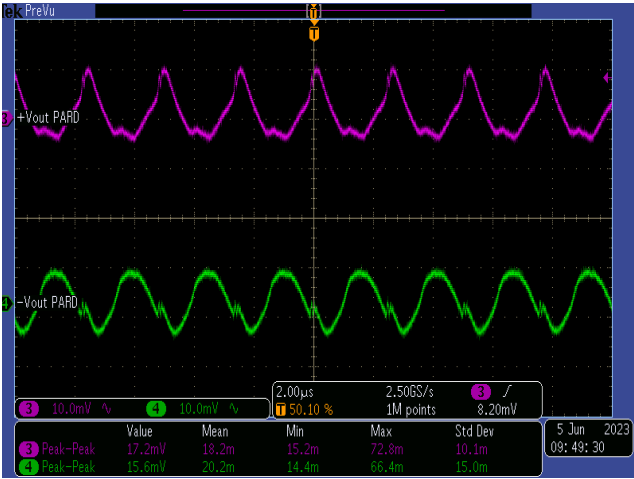

UNITS ARE PER DIVISION

MSA+2815D OUTPUT RIPPLE
FIGURE 27



UNITS ARE PER DIVISION

MSA+2805D STEP LOAD 50% - 100%
FIGURE 28



UNITS ARE PER DIVISION

MSA+2815S STEP LOAD 100% - 50%
FIGURE 29

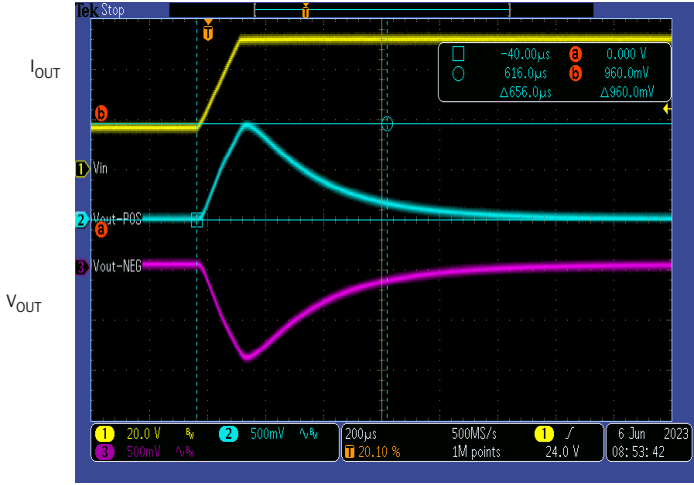

UNITS ARE PER DIVISION

MSA+2805 STEP LINE 15 - 50V FULL LOAD
FIGURE 30

MSA+ Single and Dual DC-DC Converters

PRELIMINARY - 15 TO 50 VOLT INPUT - 6 WATT

TYPICAL PERFORMANCE PLOTS: 25 °C CASE, 28 VIN, 100% LOAD, UNLESS OTHERWISE SPECIFIED.
FOR REFERENCE ONLY, NOT GUARANTEED SPECIFICATIONS.



UNITS ARE PER DIVISION
MSA+2805D STEP LINE 50 - 15V FULL LOAD
FIGURE 31

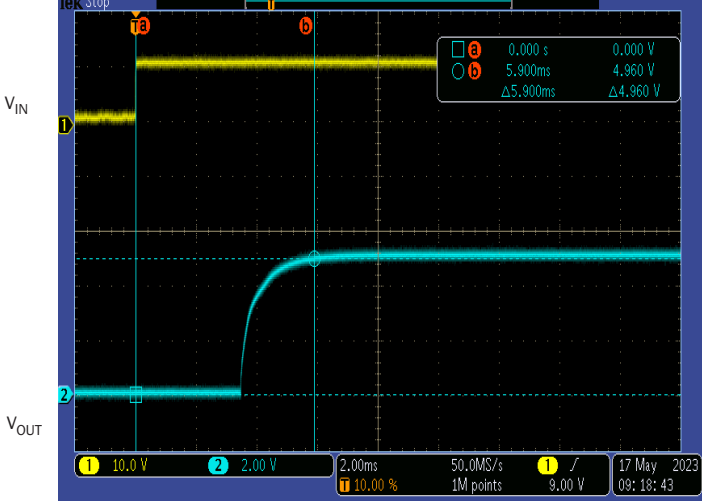

UNITS ARE PER DIVISION
MSA+2805D START-UP RESPONSE FULL LOAD
FIGURE 32

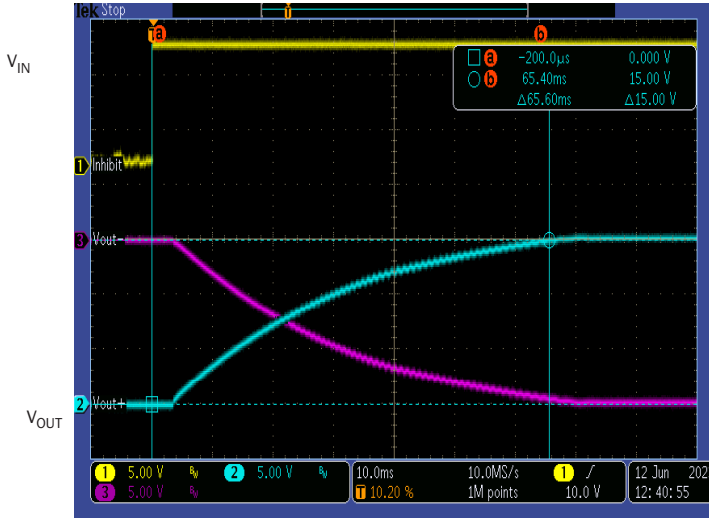

UNITS ARE PER DIVISION
MSA+2805D START-UP RESPONSE FULL LOAD W 500UF CAP
FIGURE 33

MSA+ Single and Dual DC-DC Converters

PRELIMINARY - 15 TO 50 VOLT INPUT - 6 WATT

BOTTOM VIEW CASE D6 MSA+ OFFSET FLANGE

Flanged cases: Designator "F" required in Case Option position of model number

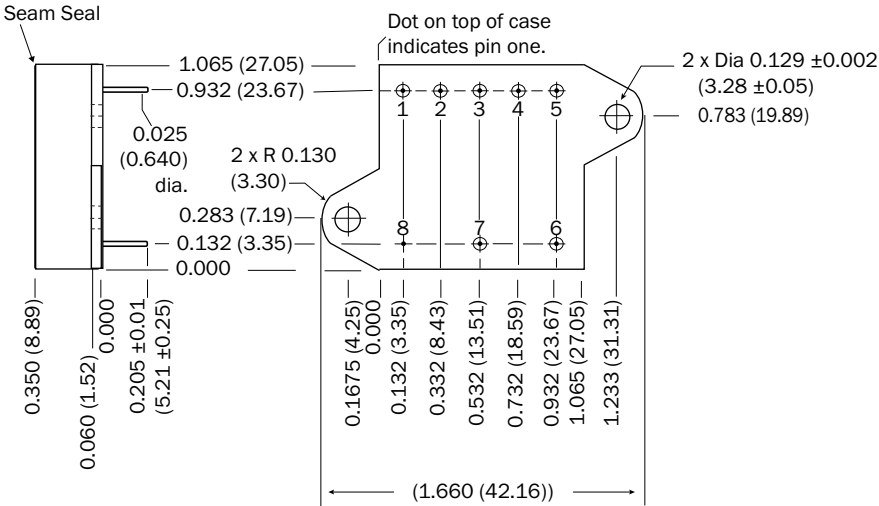

Weight: 25 grams maximum

Case dimensions in inches (mm)
Tolerance ±0.005 (0.13) for three decimal places
±0.01 (0.3) for two decimal places
unless otherwise specified

CAUTION
Heat from reflow or wave soldering may damage the device.
Solder pins individually with heat application
not exceeding 300 °C for 10 seconds per pin.

Materials
Header Cold Rolled Steel/Nickel/Gold
Cover Cold Rolled Steel/Nickel
Pins #52 alloy, gold, compression seal
Gold plating of 50 - 100 microinches included in pin diameter
Seal hole: 0.070 ±0.003 (1.78 ±0.08)

FIGURE 7: MSA+ OFFSET FLANGED CASE DIMENSIONS

MSA+ Single and Dual DC-DC Converters

PRELIMINARY - 15 TO 50 VOLT INPUT - 6 WATT

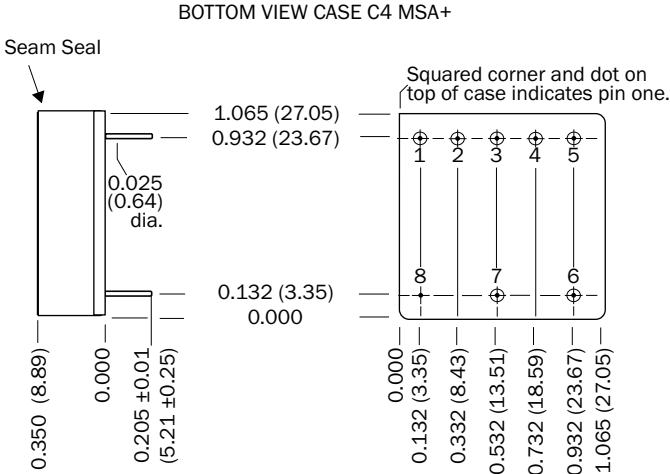

Weight: 23 grams maximum

Case dimensions in inches (mm)
Tolerance ±0.005 (0.13) for three decimal places
±0.01 (0.3) for two decimal places
unless otherwise specified

CAUTION
Heat from reflow or wave soldering may damage the device.
Solder pins individually with heat application
not exceeding 300°C for 10 seconds per pin.

Materials
Header Cold Rolled Steel/Nickel/Gold
Cover Cold Rolled Steel/Nickel
Pins #52 alloy, gold, compression seal
Gold plating of 50 - 100 microinches included in pin diameter
Seal hole: 0.070 ±0.003 (1.78 ±0.08)

Please refer to the numerical dimensions for accuracy.

FIGURE 8: MSA+ CASE DIMENSIONS

MSA+ Single and Dual DC-DC Converters

PRELIMINARY - 15 TO 50 VOLT INPUT – 6 WATT

ELEMENT EVALUATION TABLES FOR QML PRODUCTS ARE IN “APP-009 QUALITY AND CERTIFICATION”, APPENDIX A, IN COMPLIANCE WITH MIL-PRF-38534 REVISION L.
(LINK [HTTPS://WWW.CRANEAE.COM/QUALITY-ASSURANCE-MODULAR-POWER](https://www.craneae.com/quality-assurance-modular-power))

ENVIRONMENTAL SCREENING HIGH RELIABILITY STANDARD, /ES, /SX AND /883 (CLASS H)

TEST PERFORMED	NON-QML ¹			CLASS H QML ²	
	STANDARD	/ES	/SX	/883 CH ³	/883 QML ⁴
Pre-cap Inspection, Method 2017, 2032	■	■	■	■	■
Temperature Cycle (10 times)					
Method 1010, Cond. C, -65°C to +150°C, ambient			■	■	■
Method 1010, Cond. B, -55°C to +125°C, ambient		■			
Constant Acceleration					
Method 2001, 3000 g			■	■	■
Method 2001, 500 g		■			
PIND, Test Method 2020, Cond. A			■ ⁵	■ ⁵	■ ⁵
Burn-in Method 1015, +125°C case, typical ⁶					
96 hours		■			
160 hours			■	■	■
Final Electrical Test, MIL-PRF-38534, Group A,					
Subgroups 1 through 6, -55°C, +25°C, +125°C case			■	■	■
Subgroups 1 and 4, +25°C case	■	■			
Hermeticity Test, Method 1014					
Gross Leak, Cond. C ₁ , fluorocarbon		■	■	■	■
Fine Leak, Cond. A ₂ , helium		■	■	■	■
Gross Leak, Dip	■				
Final visual inspection, Method 2009	■	■	■	■	■

Test methods are referenced to MIL-STD-883 as determined by MIL-PRF-38534.

Notes

1. Non-QML products may not meet all of the requirements of MIL-PRF-38534.
2. All processes are QML qualified and performed by certified operators.
3. Class H QML products with no SMD number are marked “CH” per MIL-PRF-38534, 3.9.5.8.3, Table III.
4. Class H QML products have an SMD number
5. Not required by DLA but performed to assure product quality.
6. Burn-in temperature designed to bring the case temperature to +125°C minimum. Burn-in is a powered test.

TABLE 10: ENVIRONMENTAL SCREENING

