

# FMCE-0828 EMI Input Filters

## 28 VOLT INPUT – 8 AMP

### FEATURES

- Attenuation to 60 dB at 500 kHz, typical
- Operating temperature -55° to +125°C
- Nominal 28 volt input, -0.5 to 50 volt operation
- Transient rating -0.5 to 80 volts for 1 second
- Up to 8 amp throughput current over the full input voltage range of -0.5 to 50 volts
- Compliant to
  - MIL-STD-461C CE03
  - MIL-STD-461D, E and F CE102
  - MIL-STD-461C CS01
  - MIL-STD-461D, E and F CS101
- Compatible with MIL-STD-704 A-E dc voltage transient surges



FMCE-0828	
INPUT (V)	CURRENT (A)
0 - 50	8

### DESCRIPTION

The Interpoint® FMCE-0828 Series™ of EMI filters offers up to 8 amps of throughput current in a low profile package. The FMCE-0828 filters are manufactured in our fully certified and qualified MIL-PRF-38534 Class H production facility and packaged in hermetically sealed steel cases. They are ideal for use in programs requiring high reliability and small size. The FMCE-0828 filter is specifically designed to reduce the input line reflected ripple current of Interpoint high frequency DC-DC converters such as MFX, MTR, MWR, MHF+, MHV and MOR Series. One filter can be used with multiple converters up to the rated output current of the filter.

### INPUT RIPPLE AND EMI

Switching DC-DC converters naturally generate two noise components on the power input line: differential noise and common mode noise. Input ripple current refers to both of these components. Differential noise occurs between the positive input and input common. Most Interpoint converters have an input filter that reduces differential noise which is sufficient for many applications. Common mode noise occurs across stray capacitances between the converter's power train components and the baseplate (bottom of the package) of the converter.

Where low noise currents are required to meet CE03 of MIL-STD-461C and/or CE102 of MIL-STD-461D, E and F, a power line filter is needed. The FMCE-0828 EMI power line filters reduce the common mode and differential noise generated by the converters. FMCE-0828 filters reduce input ripple current by 60 dB, typical, at 500 kHz and 1 MHz when used in conjunction with Interpoint DC-DC converters. When used with an Interpoint converter, performance exceeds the CE03 test of MIL-STD-461C and meets the requirements of CS01 of MIL-STD-461C. These filters also meet CE102 and CS101 of MIL-STD-461D, E and F.

Place the filter as close as possible to the converter for optimum performance. The baseplates of the filter and the converter should be connected with the shortest and widest possible conductors.

### TRANSIENTS

A transient of -0.5 to 80 volts (0.5 ohm source impedance) will not damage the filter but will be passed on to the converter.

### OPERATION OVER TEMPERATURE

The FMCE-0828 Series filters are rated for full power operation from -55°C to +125°C case temperature. Current is derated linearly to 80% at +135°C case temperature. See Table 7 on page 10 and Table 8 on page 11.

### INSERTION LOSS

The maximum dc insertion loss at full load and nominal input voltage represents a power loss of less than 3%.

### PACKAGING

FMCE-0828 filters are sealed in metal hermetic, down-ledged packages non-flanged (Case F5, Figure 11 on page 7) or flanged (Case J6, Figure 12 on page 8) available on DLA Drawings. See DLA Cross Reference, Table 3 on page 4. Also available in a side-ledged package (Case U, Figure 13 on page 9).

# FMCE-0828 EMI Input Filters

## 28 VOLT INPUT – 8 AMP

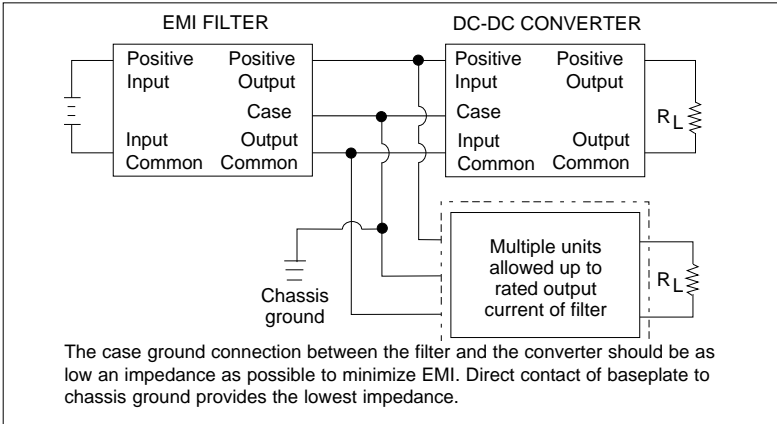

FIGURE 1: CONNECTION DIAGRAM

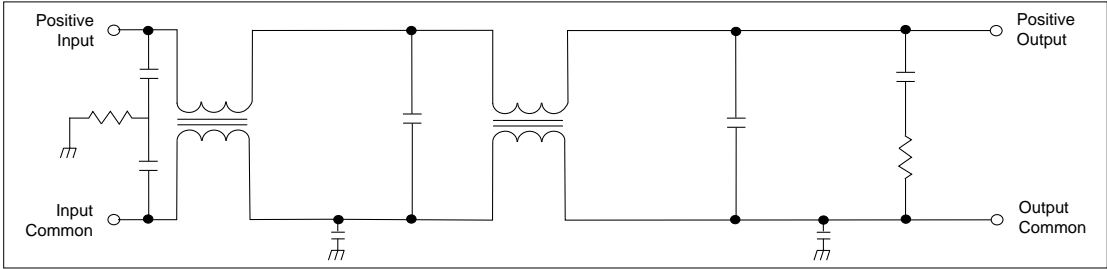

FIGURE 2: SCHEMATIC FMCE-0828

# FMCE-0828 EMI Input Filters

## 28 VOLT INPUT – 8 AMP

### PIN OUT DOWN-LEADED MODEL

PIN OUT	
Pin	Designation
1	Positive Input
2	Positive Output
3	Output Common
4	Case Ground <sup>1</sup>
5	Input Common

Notes  
 1. Although the down-leaded packages can be connected to chassis ground with the case ground lead, direct contact of the base plate to chassis improves EMI performance.

TABLE 1: PIN OUT DOWN -LEADED

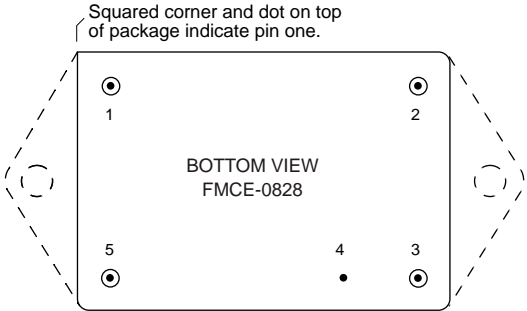

Dotted line shows flanged package option.  
 See Figure 11 on page 7 and Figure 12 on page 8 for dimensions.

FIGURE 3: PIN OUT FMCE-0828

### PIN OUT SIDE-LEADED MODEL

PIN OUT	
Pin	Designation
1, 2, 3	Positive Input
4, 5, 6	Input Common
7, 8, 9	Output Common
10, 11, 12	Positive Output
Bottom of case	Case Ground

Notes  
 1. All pins must be connected.  
 2. The baseplate is the only case ground connection and should directly contact chassis ground.

TABLE 2: PIN OUT SIDE-LEADED

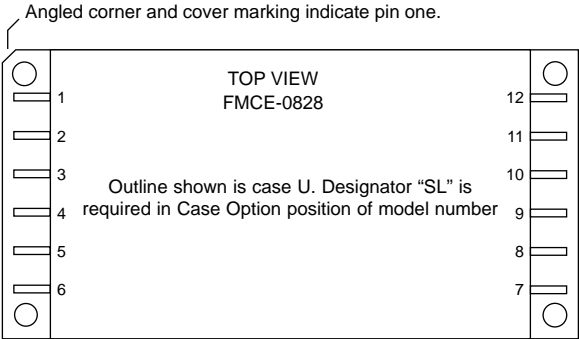

See Figure 13 on page 9 for dimensions.

FIGURE 4: PIN OUT FMCE-0828-SL

# FMCE-0828 EMI Input Filters

## 28 VOLT INPUT – 8 AMP

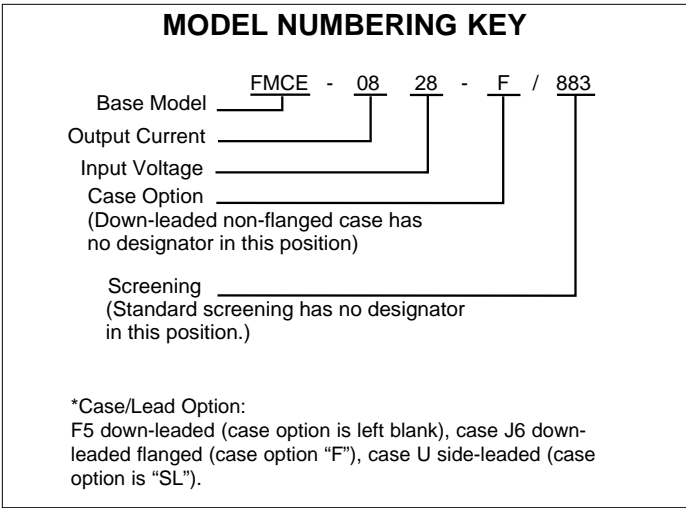

DLA NUMBERS	
DLA DRAWING (5915)	FMCE-0828 SIMILAR PART
10017-01HXC	FMCE-0828/883
10017-01HZC	FMCE-0828-F/883
For exact specifications for a DLA product, refer to the DLA drawing. DLA drawings can be downloaded from: <a href="https://landandmaritimeapps.dla.mil/programs/smcr/">https://landandmaritimeapps.dla.mil/programs/smcr/</a>	

TABLE 3: DLA CROSS REFERENCE

FIGURE 5: MODEL NUMBERING KEY

<b>MODEL NUMBER OPTIONS <sup>1</sup></b> TO DETERMINE THE MODEL NUMBER ENTER ONE OPTION FROM EACH CATEGORY IN THE FORM BELOW.			
CATEGORY	Base Model and Input Voltage	Case Option <sup>2</sup>	Screening <sup>3</sup>
<b>OPTIONS</b>	FMCE-0828	(Standard, leave blank) F (flanged) SL (side-leaded, only standard or ES)	(standard, leave blank) ES 883
<b>FILL IN FOR MODEL # <sup>4</sup></b>	FMCE-0828	_____	/ _____
Notes 1. See Figure 4 above for an example of a model number. 2. Case Options: For the standard case, Figure 11 on page 7, leave the case option blank. For the flanged case option, Figure 12 on page 8, insert the letter F in the Case Option position. For the side-leaded case option, Figure 13 on page 9, insert the letter SL. The "SL" case option is only available with standard or /ES screening). 3. Screening: For "standard" screening, leave blank. See Table 7 on page 10 and Table 8 on page 11 for more information. Use "ES" for "ES" screening and "883" for Class H (MIL-PRF-38534) screening. 4. If ordering by model number add a "-Q" to request solder dipped leads (FMCE-0828/883-Q).			

TABLE 4: MODEL NUMBER OPTIONS

# FMCE-0828 EMI Input Filters

## 28 VOLT INPUT – 8 AMP

TABLE 5: OPERATING CONDITIONS 25°C CASE, 28 VIN, UNLESS OTHERWISE SPECIFIED

MODEL		FMCE-0828			UNITS
PARAMETER	CONDITIONS	MIN	TYP	MAX	
LEAD SOLDERING TEMPERATURE <sup>1</sup>	10 seconds max.	—	—	300	°C
STORAGE TEMPERATURE <sup>1</sup>		-65	—	+150	°C
CASE OPERATING TEMPERATURE <sup>1</sup>	FULL POWER	-55	—	+125	°C
	ABSOLUTE	-55	—	+135	
DERATING OUTPUT POWER/CURRENT <sup>1</sup>	LINEARLY	From 100% at 125°C to 80% at 135°C			
ESD RATING <sup>1, 2</sup>	MIL-STD-883, METHOD 3015	≥8000			V
MIL-PRF-38534, 3.9.5.8.2	CLASS 3B				
ISOLATION, ANY PIN TO CASE EXCEPT CASE PIN	500 VDC AT 25°C	100	—	—	Megohms

## Notes

- Guaranteed by characterization test and/or analysis. Not a production test.
- Passes 8000 volts.

TABLE 6: ELECTRICAL CHARACTERISTICS: -55°C TO +125°C CASE, UNLESS OTHERWISE SPECIFIED.

MODEL		FMCE-0828 CASE F5 OR J6			FMCE-0828 CASE U			UNITS
PARAMETER	CONDITIONS	MIN	TYP	MAX	MIN	TYP	MAX	
INPUT VOLTAGE <sup>1</sup>	CONTINUOUS	-0.5	28	50	-0.5	28	50	V
	TRANSIENT, 1 second <sup>2</sup>	-0.5	—	80	-0.5	—	80	
NOISE REJECTION	500 kHz	50	60	—	50	60	—	dB
	1 MHz	50	60	—	50	60	—	
DC RESISTANCE (R <sub>DC</sub> )	25°C	—	0.080	0.110	—	0.080	0.125	ohms
CAPACITANCE T <sub>C</sub> = 25°C	ANY PIN TO CASE EXCEPT CASE PIN	50,000	60,000	70,000	50,000	60,000	70,000	pF
OUTPUT VOLTAGE <sup>1, 3</sup>	STEADY STATE	$V_{OUT} = V_{IN} - I_{IN}(R_{DC})$			$V_{OUT} = V_{IN} - I_{IN}(R_{DC})$			V
OUTPUT CURRENT <sup>1</sup>	STEADY STATE	—	—	8	—	—	8	A
POWER DISSIPATION <sup>1</sup>	T <sub>C</sub> = 25°C	—	5.1	7.0	—	5.1	7.8	W

## Note

- Guaranteed by characterization test and/or analysis. Not a production test.
- 0.5 ohm source impedance. The transient voltage can be present at the filter's output.
- Typical applications result in V<sub>OUT</sub> within 3% of V<sub>IN</sub>.

# FMCE-0828 EMI Input Filters

## 28 VOLT INPUT – 8 AMP

Typical Performance Curves: 25°C T<sub>C</sub>, nominal V<sub>in</sub>, unless otherwise specified.

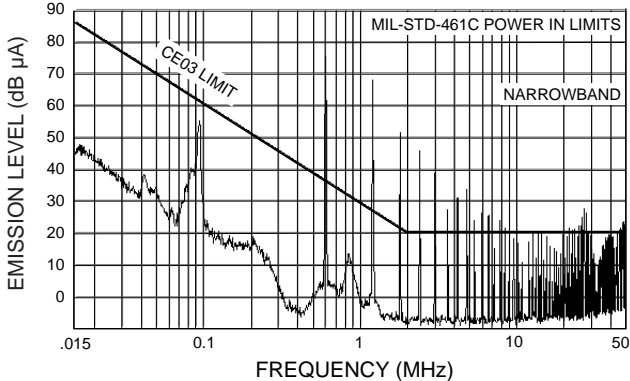

Three paralleled and synchronized MFL2815D converters without filtering.

FIGURE 6

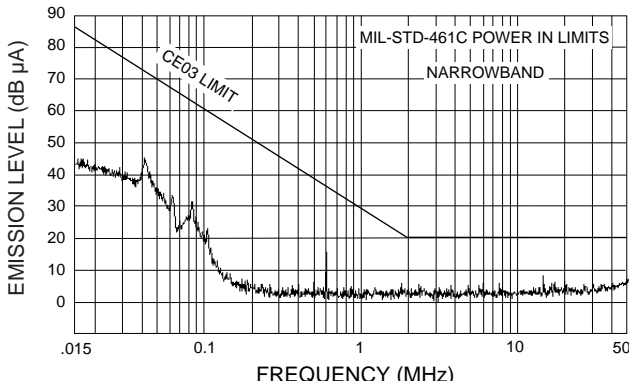

CE03: Three paralleled and synchronized MFL28 converters with an FMCE-0828.

FIGURE 7

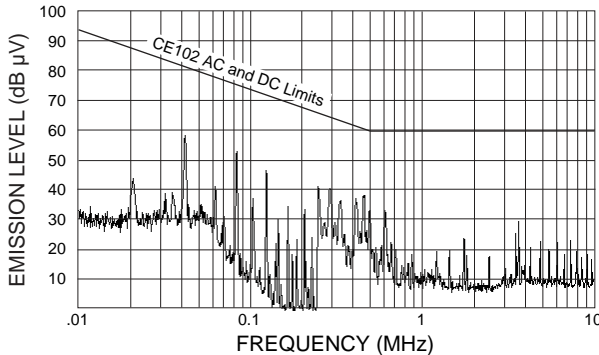

CE102: Three paralleled and synchronized MFL28 converters with an FMCE-0828.

FIGURE 8

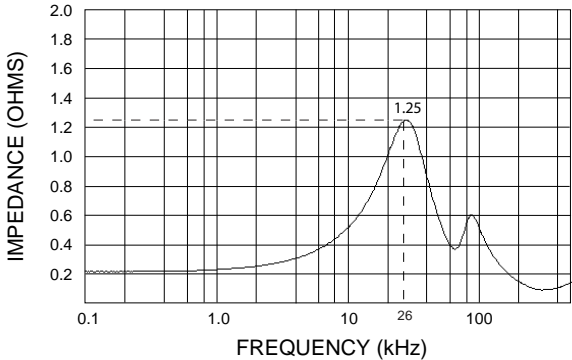

FMCE-0828 Output Impedance (measured at the output with input pins shorted)

FIGURE 9

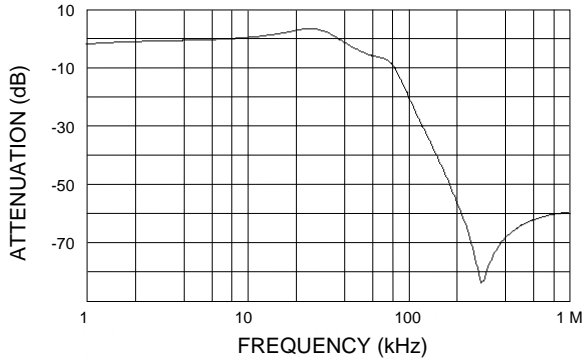

FMCE-0828 Attenuation

FIGURE 10

# FMCE-0828 EMI Input Filters

## 28 VOLT INPUT – 8 AMP

BOTTOM VIEW CASE F5

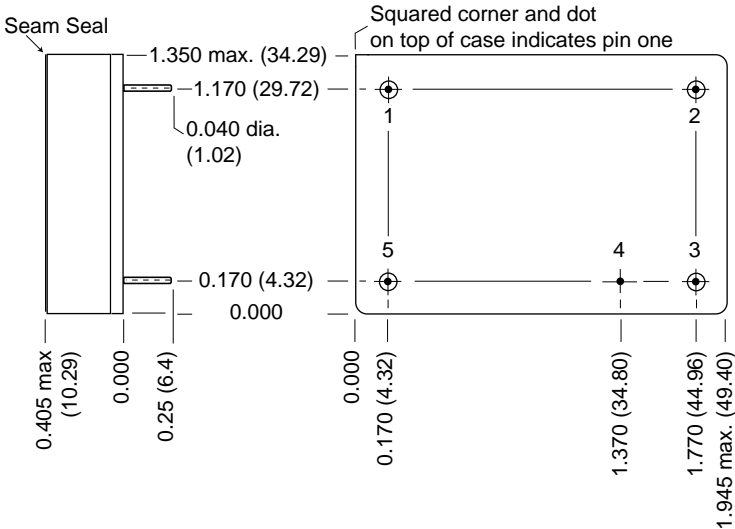

**Weight:** 60 grams maximum

**Case dimensions in inches (mm)**  
Tolerance  $\pm 0.005$  (0.13) for three decimal places  
 $\pm 0.01$  (0.3) for two decimal places  
unless otherwise specified

**CAUTION**  
Heat from reflow or wave soldering may damage the device.  
Solder pins individually with heat application not exceeding 300°C for 10 seconds per pin.

**Materials**  
Header Cold Rolled Steel/Nickel/Gold  
Cover Kovar/Nickel  
Pins #52 alloy/Gold ceramic seal  
Seal hole  $0.120 \pm 0.002$  ( $3.05 \pm 0.05$ )

Please refer to the numerical dimensions for accuracy.

FIGURE 11: CASE F5

# FMCE-0828 EMI Input Filters

## 28 VOLT INPUT – 8 AMP

### BOTTOM VIEW CASE J6

Flanged cases: Designator "F" required in Case Option position of model number.

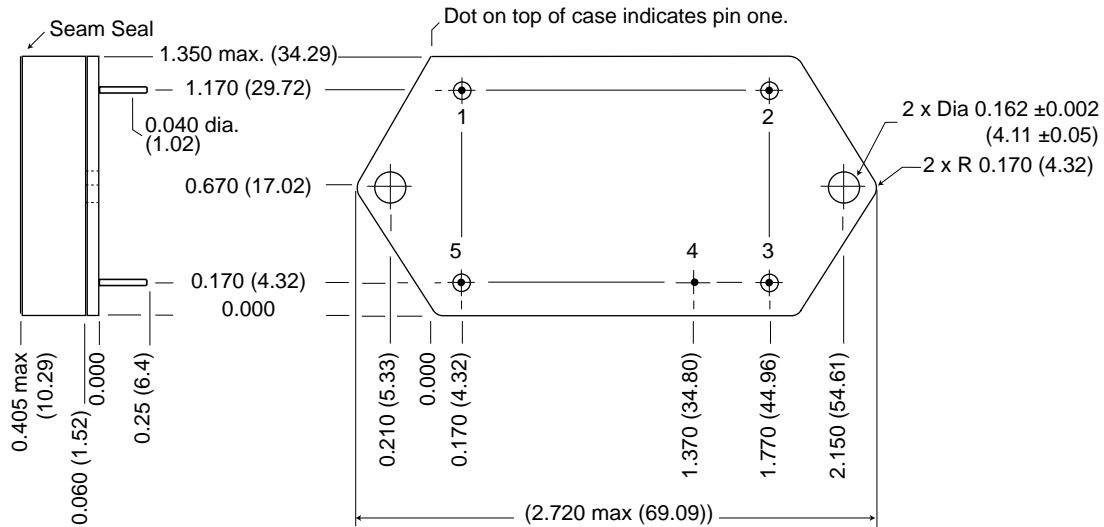

**Weight:** 60 grams maximum

#### Case dimensions in inches (mm)

Tolerance  $\pm 0.005$  (0.13) for three decimal places  
 $\pm 0.01$  (0.3) for two decimal places  
 unless otherwise specified

#### CAUTION

Heat from reflow or wave soldering may damage the device. Solder pins individually with heat application not exceeding 300°C for 10 seconds per pin.

#### Materials

Header Cold Rolled Steel/Nickel/Gold  
 Cover Kovar/Nickel  
 Pins #52 alloy/Gold ceramic seal.  
 Seal Hole:  $0.120 \pm 0.002$  ( $3.04 \pm 0.05$ )

Please refer to the numerical dimensions for accuracy.

FIGURE 12: CASE J6



# FMCE-0828 EMI Input Filters

## 28 VOLT INPUT – 8 AMP

### TOP VIEW CASE U Flanged case, short leads

Case "U" does not require an option in the Case Option position of the model number.

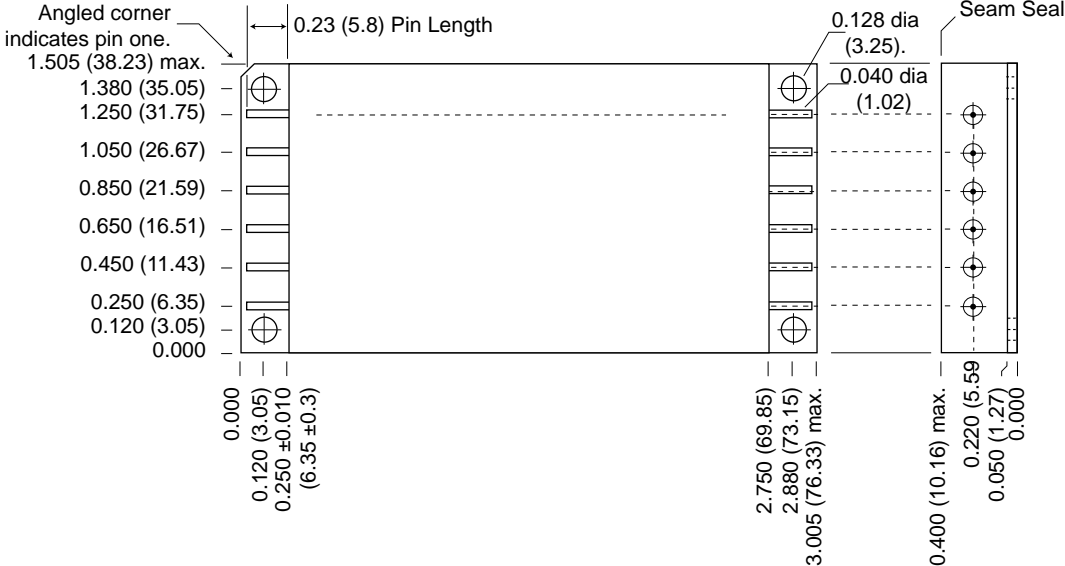

**Weight:** 86 grams maximum

**Case dimensions in inches (mm)**

Tolerance  $\pm 0.005$  (0.13) for three decimal places  
 $\pm 0.01$  (0.3) for two decimal places  
unless otherwise specified

**CAUTION**

Heat from reflow or wave soldering may damage the device. Solder pins individually with heat application not exceeding 300°C for 10 seconds per pin.

**Materials**

- Header Cold Rolled Steel/Nickel/Gold
- Cover Kovar/Nickel
- Pins #52 alloy/Gold ceramic seal
- Gold plating of 50 - 150 microinches is included in pin diameter
- Seal Hole: 0.120  $\pm$  0.002 (3.05  $\pm$  0.05)

Please refer to the numerical dimensions for accuracy.

FIGURE 13: CASE U

# FMCE-0828 EMI Input Filters

## 28 VOLT INPUT – 8 AMP

### ELEMENT EVALUATION <sup>1</sup> HIGH RELIABILITY DC-DC CONVERTERS AND EMI FILTERS /883 (CLASS H)

COMPONENT-LEVEL TEST PERFORMED	QML	
	CLASS H /883	
	M/S <sup>2</sup>	P <sup>3</sup>
Element Electrical	■	■
Visual	■	■
Internal Visual	■	
Final Electrical	■	■
Wire Bond Evaluation	■	■

Notes

1. Element evaluation does not apply to standard and /ES product.
2. M/S = Active components (microcircuit and semiconductor die).
3. P = Passive components, Class H element evaluation. Not applicable to standard and /ES element evaluation.

TABLE 7: ELEMENT EVALUATION

# FMCE-0828 EMI Input Filters

## 28 VOLT INPUT – 8 AMP

### ENVIRONMENTAL SCREENING HIGH RELIABILITY STANDARD, /ES AND /883 (CLASS H)

TEST PERFORMED	NON-QML <sup>1</sup>		CLASS H 2, 3
	STANDARD	/ES	/883 CH <sup>4</sup>
<b>Pre-cap Inspection, Method 2017, 2032</b>	■	■	■
<b>Temperature Cycle (10 times)</b>			
Method 1010, Cond. C, -65°C to +150°C, ambient			■
Method 1010, Cond. B, -55°C to +125°C, ambient		■	
<b>Constant Acceleration</b>			
Method 2001, 3000 g			■
Method 2001, 500 g		■	
<b>PIND, Test Method 2020, Cond. A</b>			■ <sup>5</sup>
<b>Burn-in Method 1015, +125°C case, typical <sup>6</sup></b>			
96 hours		■	
160 hours			■
<b>Final Electrical Test, MIL-PRF-38534, Group A,</b>			
Subgroups 1 through 6, -55°C, +25°C, +125°C case			■
Subgroups 1 and 4, +25°C case	■	■	
<b>Hermeticity Test</b>			
Gross Leak, Cond. C <sub>1</sub> , fluorocarbon		■	■
Fine Leak, Cond. A <sub>2</sub> , helium		■	■
Gross Leak, Dip	■		
<b>Final visual inspection, Method 2009</b>	■	■	■

Test methods are referenced to MIL-STD-883 as determined by MIL-PRF-38534.

#### Notes

1. Non-QML products may not meet all of the requirements of MIL-PRF-38534.
2. All processes are QML qualified and performed by certified operators.
3. Screened to MIL-PRF-38534.
4. Class H QML products with no SMD number are marked "CH" per MIL-STD-38534 Rev J, 3.9.5.8.3, Table III. Applies to all EMI Filters with DLA Drawings.
5. Not required by DLA but performed to assure product quality.
6. Burn-in temperature designed to bring the case temperature to +125°C minimum. Burn-in is a powered test

TABLE 8: ENVIRONMENTAL SCREENING