

STL 140 PIN-PIN LIMITER

TECHNICAL FEATURE

FEATURES

- 1 Watt CW Capability
- Wide bandwidth, 2 to 18 GHz
- Low VSWR < 2.0:1
- Internal DC Return
- Low Insertion Loss < 2.2 dB



DESCRIPTION

The STL 140 Limiter is a passive, broadband integrated assembly designed for receiver protection and power leveling applications. This is a PIN-PIN design with internal DC return. Metallurgical bonds are used to provide the reliability required by the most severe environments.

Systems applications include protection of transistor and FET amplifiers, mixers and detectors in ECM, telecommunications and radar systems.

TYPICAL TRANSFER CURVE

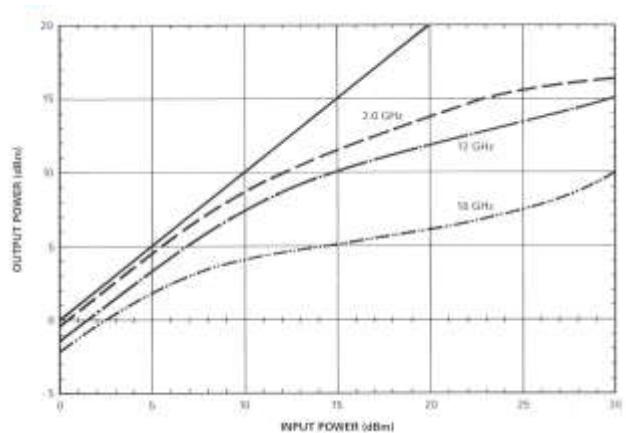

PERFORMANCE @ 25°C

| | Typical | Maximum |
|-----------------------------------|--------------|---------|
| Frequency Range | 2.0 – 18 GHz | |
| Insertion Loss (dB) ¹ | | |
| 2.0 -10.0 GHz | 0.8 | 1.2 |
| 10.0 – 18.0 GHz | 1.6 | 2.2 |
| VSWR ¹ 2.0-18.0 GHz | 1.8:1 | 2.0:1 |
| RF Leakage (dBm) ² | +15 | +19 |
| Limiting Threshold (dBm) | +8 | -- |
| Recovery Time ³ (nSec) | 50 | -- |
| Power Handling ⁴ | | |
| 1 W, CW | | |
| 50 W, 1 μ3Sec, 1 KHz PRF | | |

Outline Drawing – B1

Notes:

1. Measured at 0 dBm input.
2. Leakage measured with 1 W, CW input.
3. Measured with 50 W, 1μSec, 1 KHz pulseS.
4. Derate from +25°C to 20% at +125°C.

CIRCUIT DIAGRAM OF PIN-PIN LIMITER

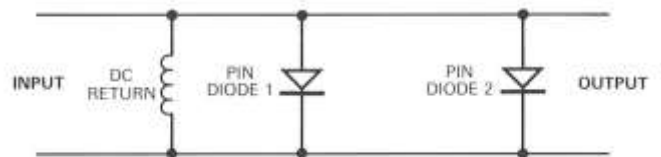

STL 140 PIN-PIN LIMITER

ENVIRONMENTAL RATINGS

- Operating Temperature.....-55°C to +125°C
- Storage Temperature-55°C to +150° C
- Temperature Cycling.....-55° C to +125°C
- Shock1500 g, 0.5 msec;
.....50 g, 11 msec
- Vibration20g, 100 to 2000 Hz
- Acceleration2000 g

TEMPERATURE DERATING OF INCIDENT POWER

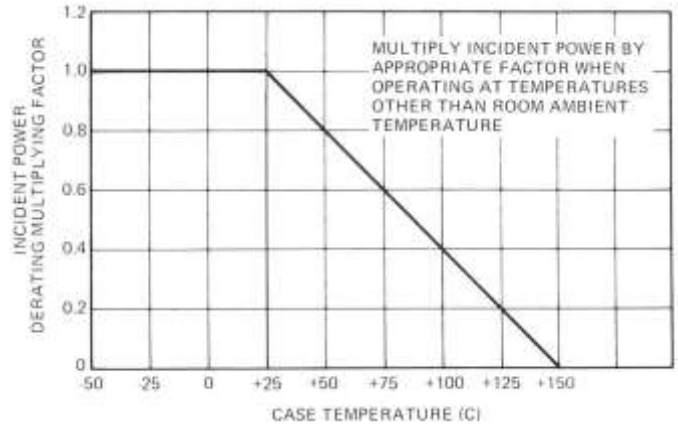

OUTLINE DRAWING

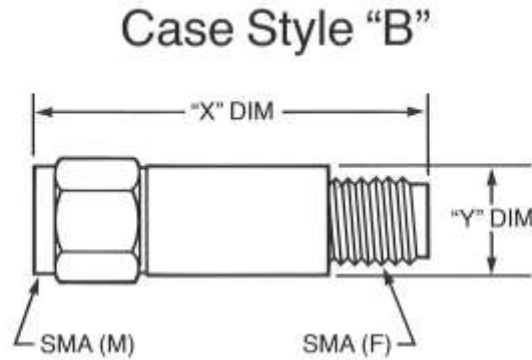

| DASH NO. | DIM "X"—INCHES/MILLIMETER | | | | DIM "Y"—INCHES/MILLIMETER | | | |
|----------|---------------------------|-------|---------|-------|---------------------------|------|---------|------|
| | MINIMUM | | MAXIMUM | | MINIMUM | | MAXIMUM | |
| | IN | MM | IN | MM | IN | MM | IN | MM |
| B1 | 1.01 | 25.65 | 1.05 | 26.67 | .310 | 7.87 | .335 | 8.51 |
| B2 | 1.14 | 28.96 | 1.18 | 29.97 | .310 | 7.87 | .335 | 8.51 |
| B3 | 1.29 | 32.77 | 1.33 | 33.78 | .310 | 7.87 | .335 | 8.51 |