

90° DIVIDERS/COMBINERS - QHM-2-6G SQ

TECHNICAL FEATURE

FEATURES

- Space Qualified
- 5.0 - 7.0 GHz
- Quadrature Hybrid, SMA



PERFORMANCE

Frequency Range.....	5.0 - 7.0 GHz
Isolation.....	20 dB min.
Insertion Loss.....	0.45 dB max.
Amplitude Balance.....	0.5 dB max.
VSWR.....	1.25:1 max.
Phase Balance.....	90° ± 4°
CW Input Power.....	10 W
Impedance.....	50 OHM nom.
Operating Temperature.....	-55° to +85° C

DESCRIPTION

The QHM-2-6G SQ Quadrature Hybrid Divider/Combiner covers 5.0 - 7.0 GHz. It uses a rugged stripline design which provides high isolation and low VSWR. This unit has been designed, manufactured and qualified per Merrimac document CENG-0001, "Standard Design Requirements for Space Qualified Devices".

PACKAGE OUTLINE

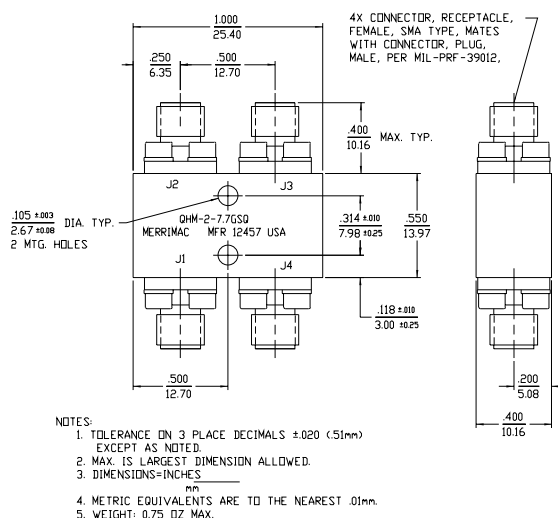

Crane Aerospace & Electronics
 Microwave Solutions – Merrimac Industries
 41 Fairfield Place, West Caldwell, NJ 07006
 + 1.973.575.1300 ext. 1309 • mw@crane-eg.com
 www.craneae.com/mw

QHM-2-6G SQ - Rev. 1, 05/21/2001

