

# PDM-60-2000H — 0° POWER DIVIDER/COMBINER

## TECHNICAL FEATURE

### FEATURES

- 1.5 - 2.5 GHz
- 6 - Way
- Hermetic Package
- Lumped Element
- Low Insertion Loss
- K-Connectors

### PRINCIPAL SPECIFICATIONS

Model Number	Frequency Range GHz	Isolation dB		Insertion Loss, dB		Phase Balance		Amplitude Balance dB		VSWR In/Out		CW Input, W, Load VSWR out		
		Min.	Typ.	Max.	Typ.	Max.	Typ.	Max.	Typ.	Max.	Typ.	1.2:1	2.0:1	∞
PDM-60-2000H	1.2 - 2.5	17	20	3.0	2.5	20	15	0.75	0.5	1.30:1	1.25:1	2	1	0.2

### GENERAL NOTES

1. The PDM-60-2000H power divider/combiner covers 1.5 to 2.5 GHz using a lumped element design for broad bandwidth and high performance.

### GENERAL SPECIFICATIONS

- Coupling .....-7.78 dB nom.  
 Impedance.....50 Ω nom.  
 Internal Load Dissipation..... 250 mW max.  
 Weight, max ..... 3 oz. (85g)  
 Operating Temperature ..... -55° to +85° C

### PACKAGE OUTLINE

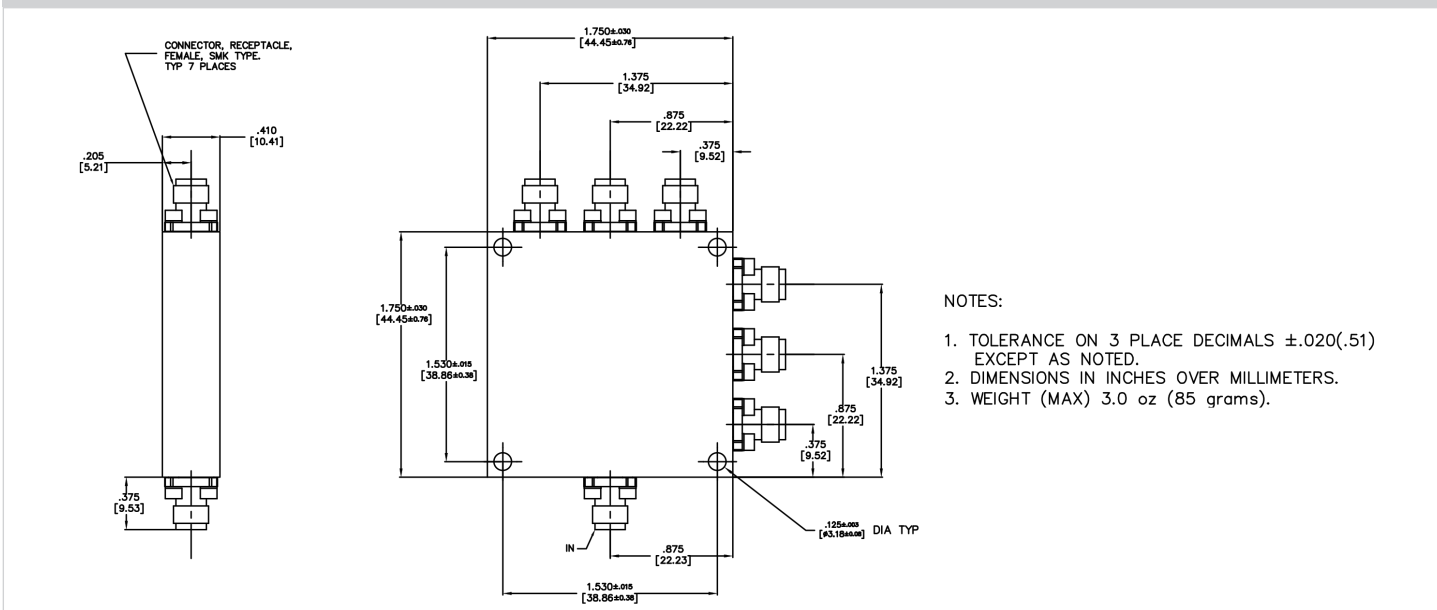

- NOTES:
1. TOLERANCE ON 3 PLACE DECIMALS ±.020(.51) EXCEPT AS NOTED.
  2. DIMENSIONS IN INCHES OVER MILLIMETERS.
  3. WEIGHT (MAX) 3.0 oz (85 grams).

