

QUAD HYBRID - QHDZ-2N-0.9G SQ

TECHNICAL FEATURE

FEATURES

- 740 - 960 MHz
 - Space Qualified
 - Multiple Plating Options
 - Excellent Phase / Amplitude Balance
- High Power Handling
 - Low Loss
 - Surface Mount
 - Tape & Reel Available



PERFORMANCE

Frequency Range	740 - 960 MHz
Isolation	- 23 dB min.
Insertion Loss	0.20 dB max.
VSWR.....	1.15:1 max.
Amplitude Balance	±0.30 dB max.
Phase Balance	90 ± 2° max.
Input Power	225 watts max.
RF Interface.....	Surface mount
Operating Temperature Range	-55 to +95°C

DESCRIPTION

The Multi-Mix[®] Zapper[®] QHDZ series provides a 3 dB 90° coupling with low insertion loss, low VSWR, and high isolation. Accurate phase and amplitude balance make this series ideal for use in IQ networks, power amplifiers, radio transceivers, receiver multicouplers and RF signal distribution and processing equipment.

QHDZ quad hybrids are fusion bonded multilayer stripline devices. The fusion bonding process yields a homogeneous monolithic dielectric structure with reliability, ruggedness, and electrical performance that is superior to conventional adhesive bonding techniques.

Parts, materials and processes are in accordance with Merrimac document CENG-0001 "Standard Design Requirements for Space Qualified Devices".

PACKAGE OUTLINE / TAPE & REEL ORIENTATION

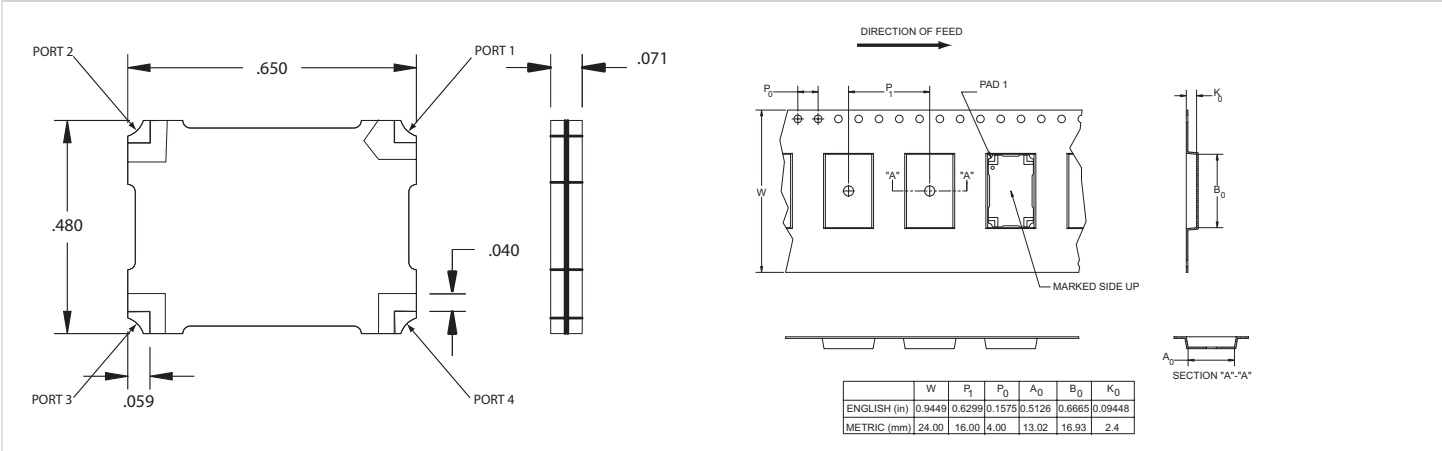

QUAD HYBRID - QHDZ-2N-0.9G SQ

PERFORMANCE DATA

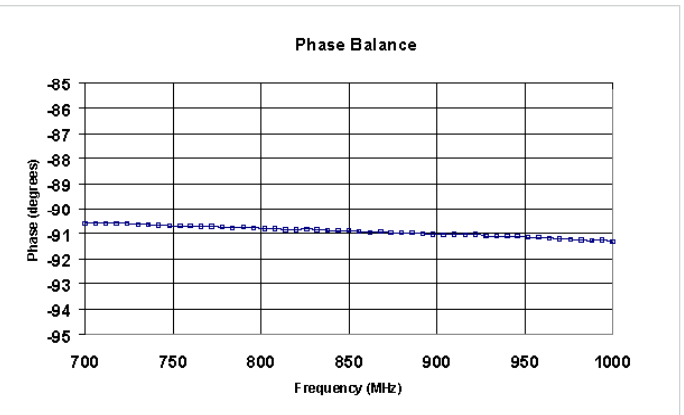
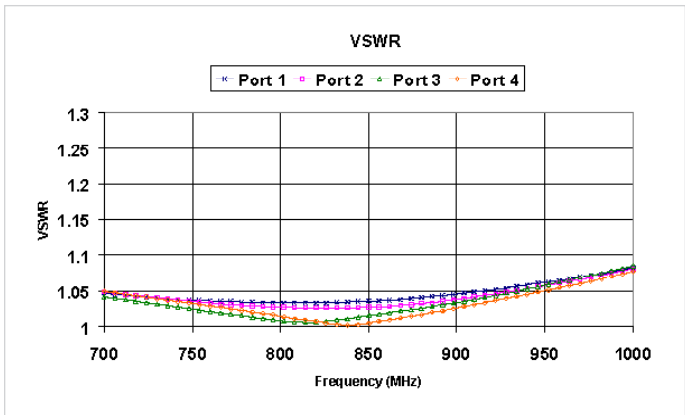
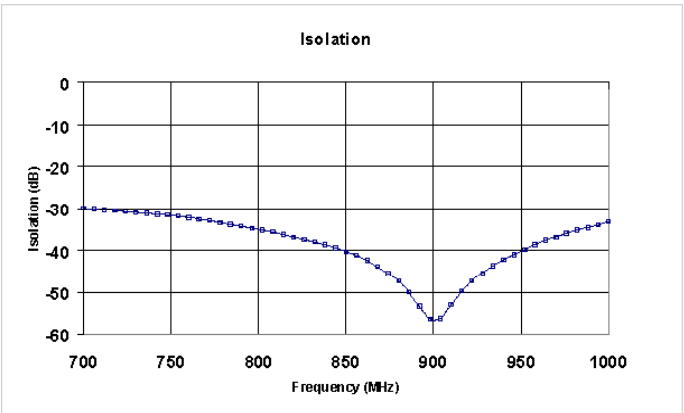
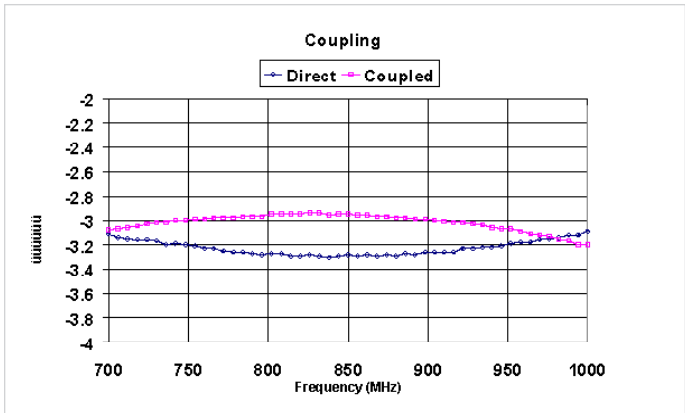

MOUNTING GUIDELINES

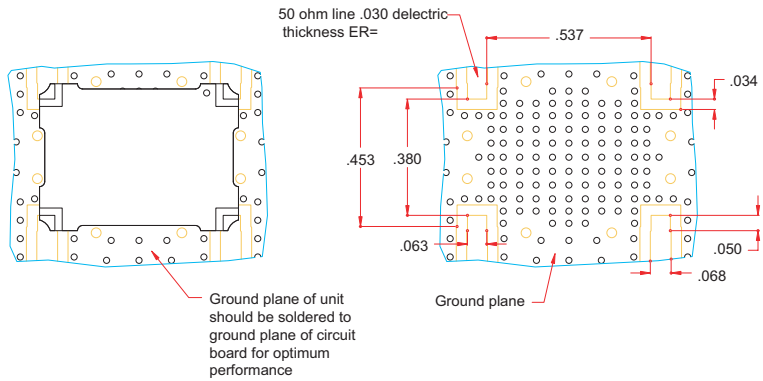

TRUTH TABLE

	1	2	3	4
1	Input	Iso	-90°	0°
2	Iso	Input	0°	-90°
3	-90°	0°	Input	Iso
4	0°	-90°	Iso	Input

