

QUAD HYBRID - QHDZ-2H-1.1G SQ

TECHNICAL FEATURE

FEATURES

- 960 - 1200 MHz
- High Isolation
- Space Qualified
- Low Loss
- Multiple Plating Options
- Surface Mount
- Excellent Phase / Amplitude Balance
- Tape & Reel Available



PERFORMANCE

Frequency Range.....	960 - 1200 MHz
Isolation.....	23 dB min.
Insertion Loss.....	0.15 dB max.
VSWR.....	1.15:1 max.
Amplitude Balance.....	±0.30 dB max.
Phase Balance.....	90 ± 2° max.
Input Power.....	200 watts max.
RF Interface.....	Surface mount
Operating Temperature Range.....	-55 to +95°C

DESCRIPTION

The Multi-Mix[®] Zapper[®] QHDZ series provides a 3 dB 90° coupling with low insertion loss, low VSWR, and high isolation. Accurate phase and amplitude balance make this series ideal for use in IQ networks, power amplifiers, radio transceivers, receiver multicouplers and RF signal distribution and process-ing equipment.

QHDZ quad hybrids are fusion bonded multilayer stripline devices. The fusion bonding process yields a homogeneous monolithic dielectric structure with reliability, ruggedness, and electrical performance that is superior to conventional adhesive bonding techniques.

Parts, materials and processes are in accordance with Merrimac document CENG-0001 "Standard Design Requirements for Space Qualified Devices".

PACKAGE OUTLINE / TAPE & REEL ORIENTATION

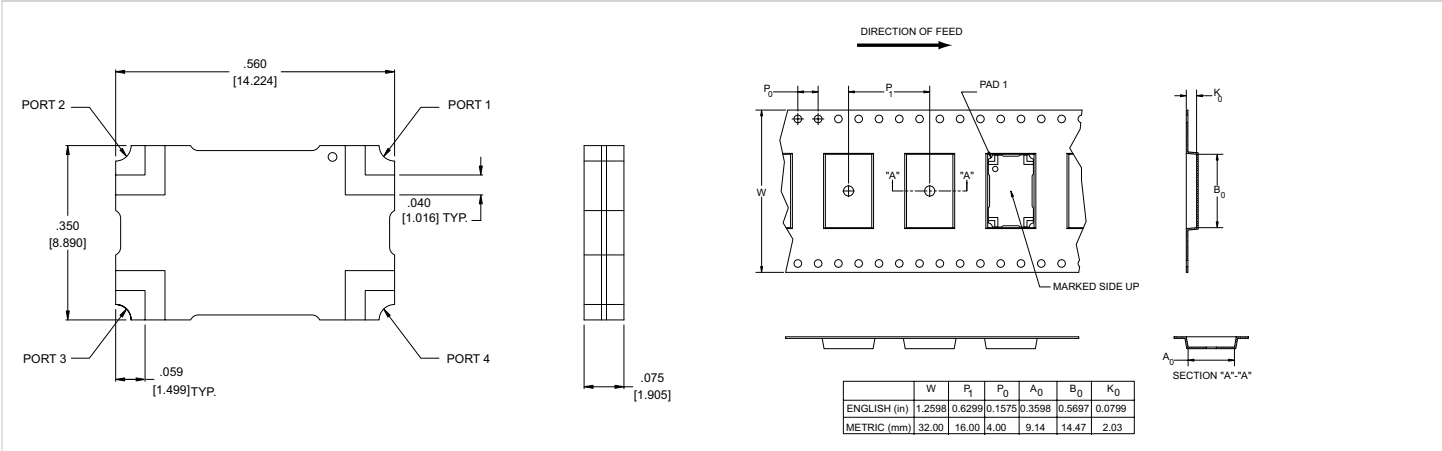

QUAD HYBRID - QHDZ-2H-1.1G SQ

PERFORMANCE DATA

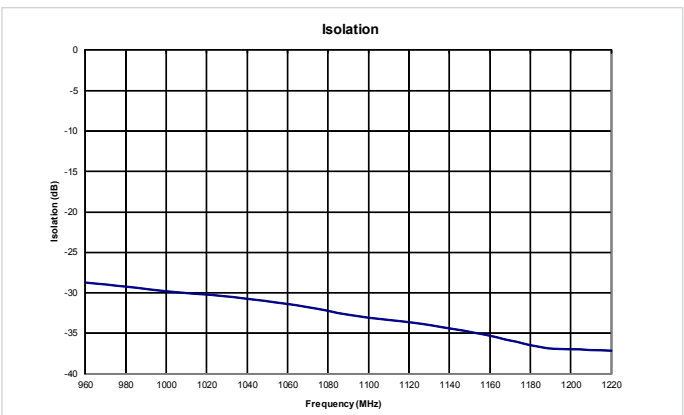
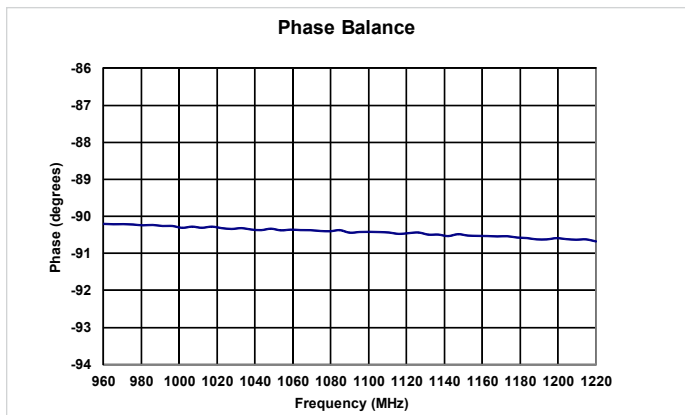
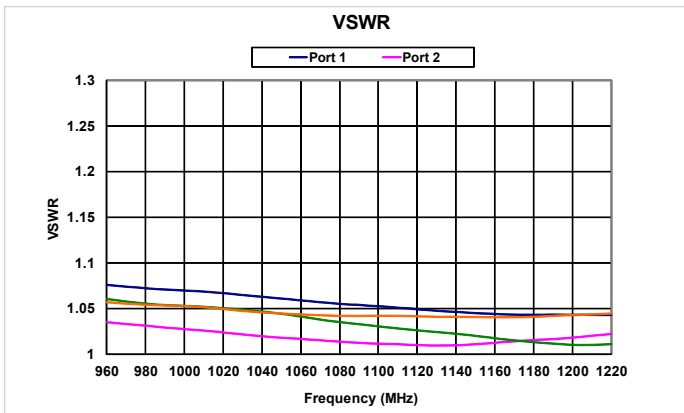
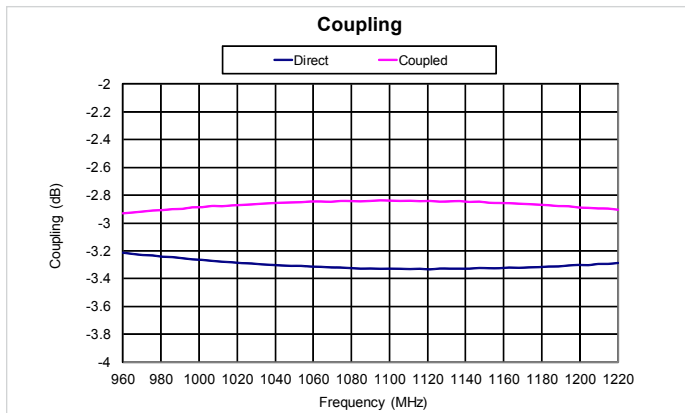

MOUNTING GUIDELINES

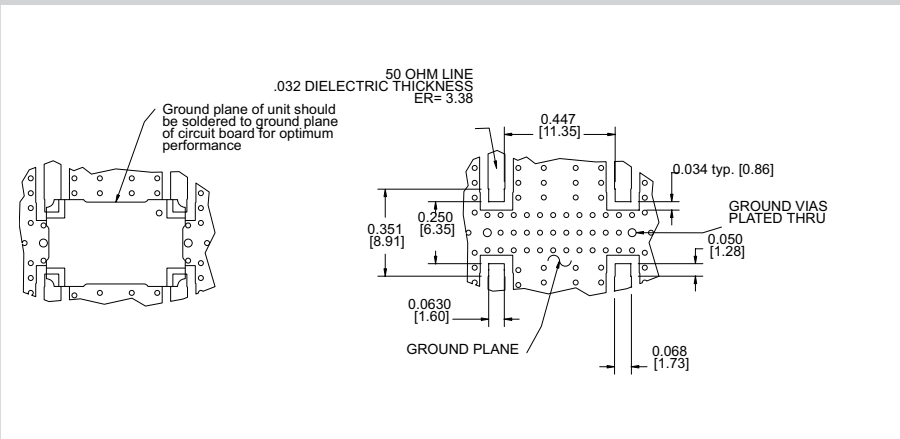

TRUTH TABLE

	1	2	3	4
1	Input	Iso	-90°	0°
2	Iso	Input	0°	-90°
3	-90°	0°	Input	Iso
4	0°	-90°	Iso	Input

DS_Quad_QHDZ2H11GSQ_022624.indd. This revision supersedes all previous releases. All technical information is believed to be accurate, but no responsibility is assumed for errors. We reserve the right to make changes in products or specifications without notice. Copyright © 2011 Crane Electronics, Inc. All rights reserved.

