

TECHNICAL FEATURE

FEATURES

- 3.3 - 3.7 GHz
- Low Loss
- Multiple Plating Options
- Space Qualified
- Surface Mount
- Tape & Reel

PRINCIPAL SPECIFICATIONS

Model Number	Frequency Range GHz	Mean Coupling dB	Insertion Loss dB Max.	Frequency Sensitivity dB Max.	VSWR, Max. All Ports	Directivity dB Min.	Input Power Max.
CSDZ-10Z-3.5G SQ	3.3 - 3.7	10.0 ± 1.0	0.25	±0.25	1.3:1	15	25 Watts

GENERAL NOTES

The Multi-Mix® CSDZ series provides 10 dB coupling at 3.3 - 3.7 GHz. The CSDZ series features accurate coupling factors, low VSWR, and high directivity. The CSDZ series is ideal for use in RF sampling networks and control circuitry in high power applications.

CSDZ directional couplers are based on fusion bonded multilayer stripline structures. The fusion bonding process yields homogeneous monolithic dielectric structures with reliability, ruggedness, and electrical and thermal performance that are superior to conventional adhesive bonding techniques.

Parts, materials and processes are in accordance with Merrimac document CENG-0001 "Standard Design Requirements for Space Qualified Devices".

GENERAL SPECIFICATIONS

Size0.175" x 0.175" x 0.047"
 Weight, max.....0.002 oz. (0.05 g)
 RF Interface.....Leadless Surface Mount
 Operating Temperature.....-55° to +95° C

TRUTH TABLE

	1	2	3	4
1	Input	Coupled	Isolated	Output
2	Coupled	Input	Output	Isolated
3	Isolated	Output	Input	Coupled
4	Output	Isolated	Coupled	Input

PACKAGE OUTLINE / TAPE & REEL ORIENTATION

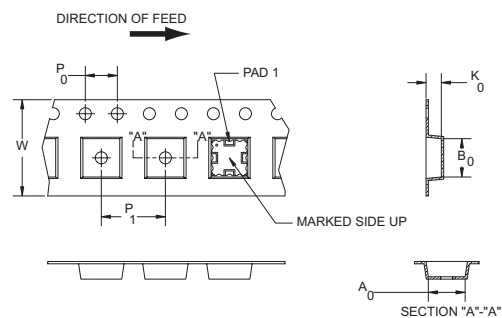
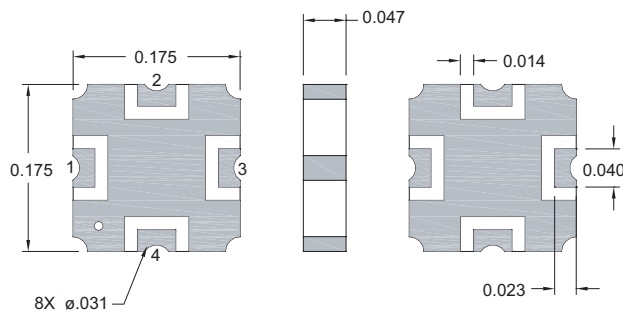

NOTES: Dimensional tolerance unless otherwise specified shall be: +/- .005"
 Thickness tolerance: +/- .005"
 Individual units will not be marked, but tape and reel packaging will include the Merrimac part # and date code. Individual units will have an index mark etched as shown on the data sheets.

	W	P ₁	P ₀	A ₀	B ₀	K ₀
ENGLISH (in)	0.4724	0.3150	0.1575	0.197	0.189	0.071
METRIC (mm)	12.00	8.00	4.00	5.0	4.8	1.8

COUPLER - CSDZ-10Z-3.5G SQ

INSERTION LOSS

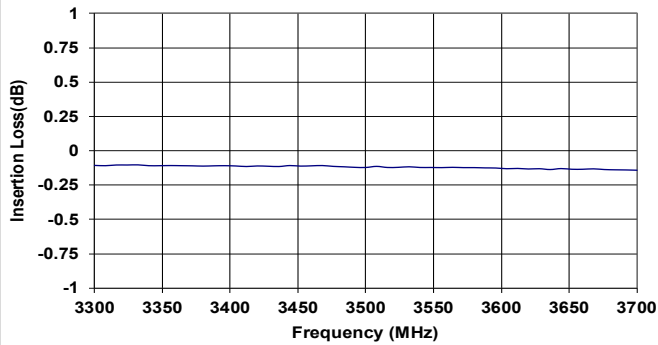

VSWR

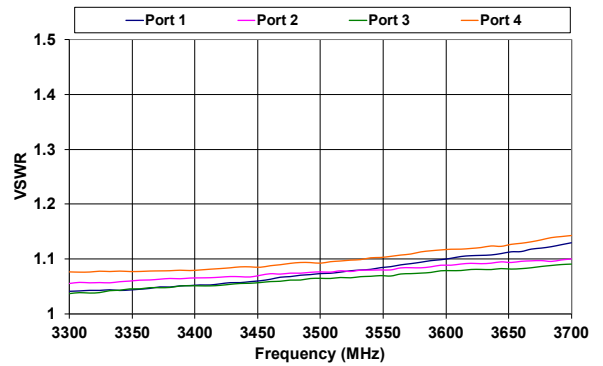

COUPLING

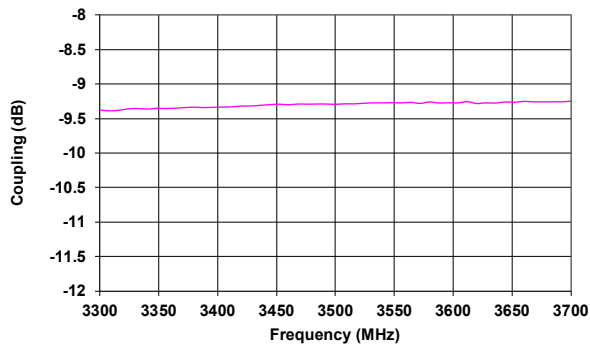

DIRECTIVITY

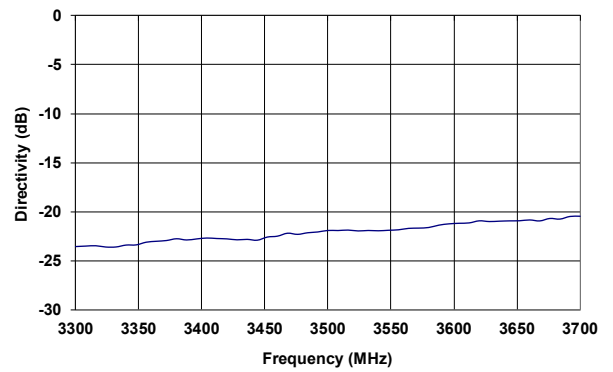

MOUNTING GUIDELINES

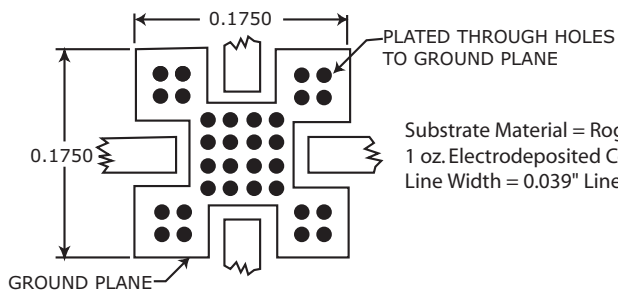

Substrate Material = Rogers RO4003; 0.020" Thickness;
 1 oz. Electrodeposited Copper Feed Transmission Lines = Grounded CPW;
 Line Width = 0.039" Line-Ground Spacing = 0.015"