



COUPLER

CSDZ-10H-0.9G SQ



TECHNICAL FEATURE

FEATURES

- 800 - 1000 MHz
- Low Loss
- Multiple Plating Options
- Space Qualified
- Surface Mount
- Tape & Reel Available

PRINCIPAL SPECIFICATIONS

| Model Number | Frequency Range MHz | Mean Coupling dB | Insertion Loss dB Max. | Frequency Sensitivity dB Max. | VSWR, Max. All Ports | Directivity dB Min. | Input Power Max. |
|------------------|---------------------|------------------|------------------------|-------------------------------|----------------------|---------------------|------------------|
| CSDZ-10H-0.9G SQ | 800 - 1000 | 10 ± 0.6 | 0.15 | ±0.15 | 1.15:1 | 23 | 250 Watts |

GENERAL NOTES

The Multi-Mix® CSDZ series provides 10 dB coupling at 900 MHz. The CSDZ series features accurate coupling factors, low VSWR, and high directivity. The CSDZ series is ideal for use in RF sampling networks and control circuitry in high power applications.

CSDZ directional couplers are based on fusion bonded multilayer stripline structures. The fusion bonding process yields homogeneous monolithic dielectric structures with reliability, ruggedness, and electrical and thermal performance that are superior to conventional adhesive bonding techniques.

Parts, materials and processes are in accordance with Merrimac document CENG-0001 "Standard Design Requirements for Space Qualified Devices".

GENERAL SPECIFICATIONS

Size 0.56" x 0.35" x 0.068"
 Weight, max..... 0.016 oz. (0.457 g)
 RF Interface.....Leadless Surface Mount
 Operating Temperature.....-55° to +95° C

TRUTH TABLE

| | 1 | 2 | 3 | 4 |
|---|----------|----------|----------|----------|
| 1 | Input | Output | Isolated | Coupled |
| 2 | Output | Input | Coupled | Isolated |
| 3 | Isolated | Coupled | Input | Output |
| 4 | Coupled | Isolated | Output | Input |

PACKAGE OUTLINE / TAPE & REEL ORIENTATION

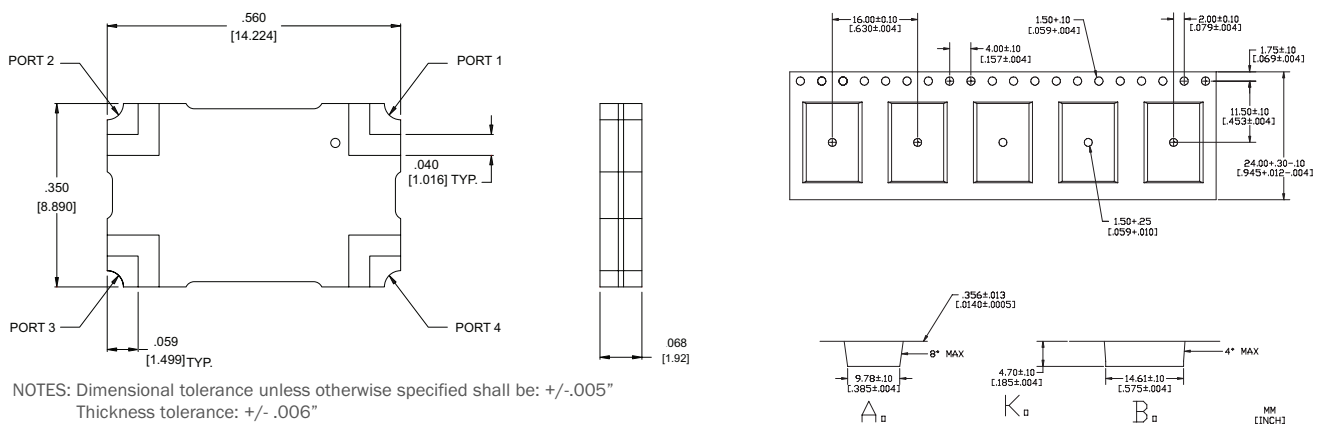

Microwave Solutions
 Merrimac Industries
 41 Fairfield Place,
 West Caldwell, NJ 07006
 + 1 973-575-1300, 191309
 info@craneae.com
 www.craneae.com

Page 1 of 1
 CSDZ-10H-0.9G SQ
 Rev. -, 02/15/2024

U.S. Patent 6,099,677 and other Patents Pending.
 DS_Coupler_CDSZ10H09GSQ_021524.indd. This revision supersedes all previous releases. All technical information is believed to be accurate, but no responsibility is assumed for errors. We reserve the right to make changes in products or specifications without notice.
 Copyright © 2021 Crane Electronics, Inc. All rights reserved.

COUPLER - CSDZ-10H-0.9G SQ

INSERTION LOSS

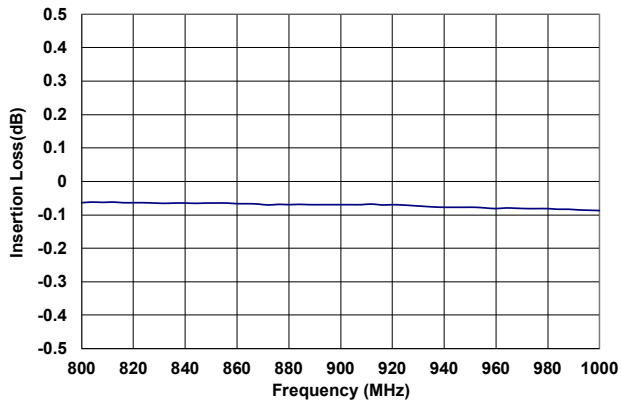

VSWR

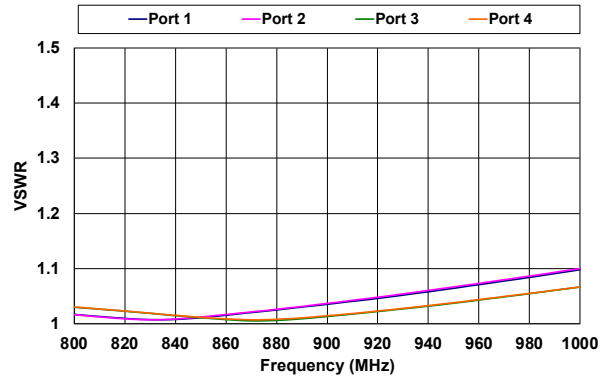

COUPLING

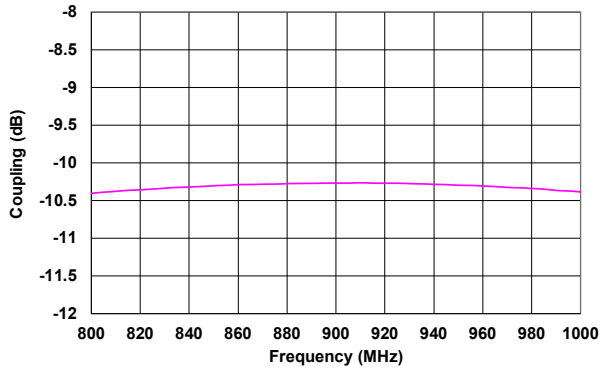

DIRECTIVITY

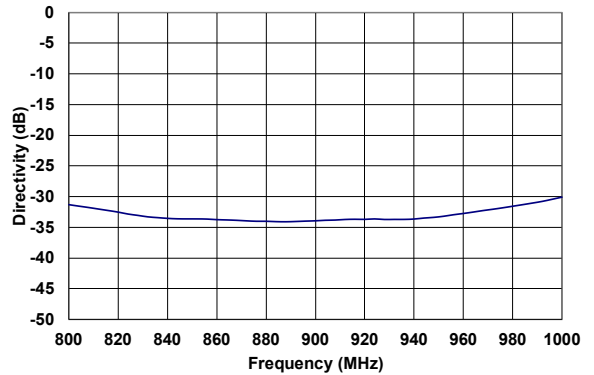

MOUNTING GUIDELINES

