

TECHNICAL FEATURE

FEATURES

- Space Qualified
- 2 - 100 MHz

PRINCIPAL SPECIFICATIONS

Model Number	Frequency Range MHz	Frequency Sensitivity dB Max.	Coupling dB	Insertion Loss, dB Max.	Directivity dB Min.	VSWR Main Max.	VSWR Coupled Max.	CW Power Rating Main Line	Weight Max.
CRM-10-50 SQ	2 - 100	+ / - 0.5	10 +/- 1.0	1.0	30	1.3:1	1.3:1	1 Watt	45 g.

TECHNICAL DESCRIPTION / APPLICATION

The CRM-10-50 SQ directional coupler covers 10 - 200 MHz. with a special lumped element design to reduce size, while maintaining high performance. manufactured and qualified per Merrimac document CENG-0001, "Standard Design Requirements for Space Qualified Devices."

PACKAGE OUTLINE

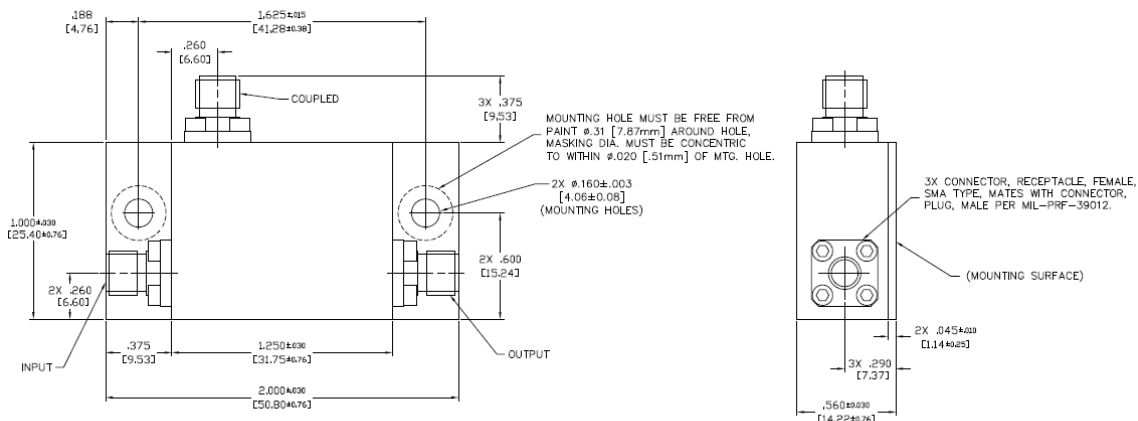

NOTES:

1. TOLERANCE ON 3 PLACE DECIMALS $\pm .020$ [.51mm] EXCEPT WHERE NOTED.
2. MAX. IS LARGEST DIMENSION ALLOWED.
3. DIMENSIONS = INCHES [mm]
4. METRIC EQUIVALENTS ARE TO THE NEAREST .01mm
5. EXTERNAL FINISH:
EXTERIOR SURFACES: FLAT BLACK POLYURETHANE COATING AEROGLAZE Z306 (EXCEPT MOUNTING SURFACE TOP MOUNTING HOLE AREA AND AREA AROUND VENT HOLES AND VENT SLOT).
MOUNTING AND UNPAINTED SURFACE FINISH:
CHEMICAL FILM PER MIL-DTL-5541, CLASS 3.
CONNECTOR FINISH: PASSIVATED.
6. WEIGHT: 1.59 OZ. [45g] MAX.