

SFME28-461 EMI Input Filters

0 TO 50 VOLT INPUT – 10 AMP

FEATURES

- Radiation tolerant space EMI filter
Total ionizing dose (TID) guaranteed per MIL-STD-883 method 1019, radiation hardness assurance (RHA) H, 1000 krad(Si)
Passive components used for maximum tolerance in space environments
- Qualified to MIL-PRF-38534 Class H and K
- Attenuation 70 dB at 500 kHz and 1 MHz, typical
- Operating temperature -55° to +125° C
- Nominal 28 V input, 0 V to 50 volts operation
- Up to 10 A throughput current
- Compliant to MIL-STD-461C CE03
- Compatible with MIL-STD-704 A-E 28 volt dc power bus

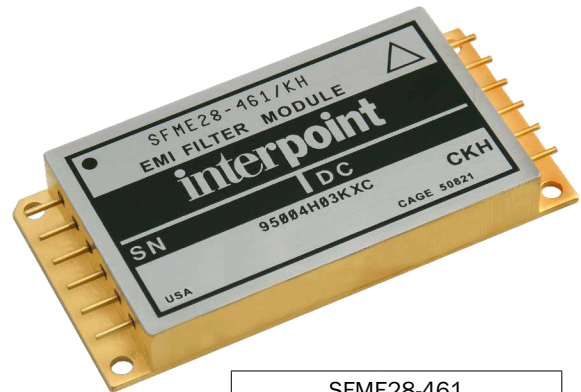

SFME28-461	
INPUT (V)	CURRENT (A)
0 - 50	10

DESCRIPTION

The Interpoint® SFME28-461™ Series EMI filter modules are specifically designed to reduce the reflected input ripple current of high frequency DC-DC converters. SFME28-461 filters minimize electromagnetic interference (EMI) for Interpoint® space converters. These filters are intended for use in 28 volt applications which must meet MIL-STD-461 levels of conducted emissions. One filter can be used with multiple converters up to the rated output current of the filter. The SFME EMI Filters offers up to 10 amps of throughput current in a radiation tolerant design. These low profile filters are manufactured in our fully certified and qualified MIL-PRF-38534 Class K production facility and packaged in hermetically sealed steel cases. They are ideal for use in programs requiring high reliability, small size, and high levels of radiation hardness assurance.

INPUT RIPPLE AND EMI

Switching DC-DC converters naturally generate two noise components on the power input line: differential noise and common mode noise. Input ripple current refers to both of these components.

Differential noise occurs between the positive input and input common. Most Interpoint converters have an input filter that reduces differential noise which is sufficient for most applications.

Common mode noise occurs across stray capacitances between the converter's power train components and the baseplate (bottom of the package) of the converter.

Where low noise currents are required to meet CE03 of MIL-STD-461, a power line filter is needed. These EMI power line filters reduce the common mode and differential noise generated by the converters. The SFME28-461 filters reduce input ripple current by a minimum of 60 dB at 500 kHz and 1 MHz when used in conjunction with Interpoint DC-DC converters.

The filter must be placed as close as possible to the converter for optimum performance. The baseplates of the filter and the converter should be connected with the shortest and widest possible conductors. For the best connection, mount the filter's and converter's baseplates on or above a small ground plane.

OPERATION OVER TEMPERATURE

All SFME28-461 filters are rated for full power operation from -55° C to +125° C case temperature. Current is derated linearly to zero at +135° C case temperature.

INSERTION LOSS

The maximum dc insertion loss at full load and nominal input voltage represents a power loss of less than 4%.

RADIATION HARDNESS ASSURANCE (RHA)

SFME28-461 is built with passive components to ensure maximum tolerance in space environments. RHA level H is guaranteed to 1000 krad(Si).

SCREENING

The SFME28-461 filter offers three screening options: Space Prototype (O), Class H, or Class K. Radiation tolerant to Radiation Hardness Assurance (RHA) levels of “-” (O) or “H”, per MIL-PRF-38534. Interpoint model numbers use an “O” in the RHA designator position to indicate the “-” (dash) RHA level of MIL-PRF-38534, which is defined as “no RHA”. See Table 6 on page 8.

SFME28-461 EMI Input Filters

0 TO 50 VOLT INPUT – 10 AMP

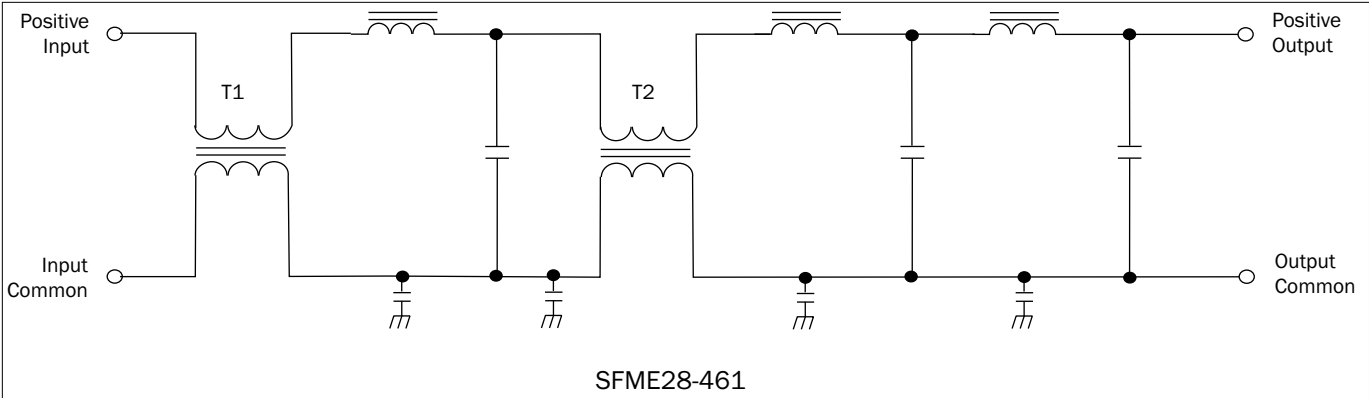
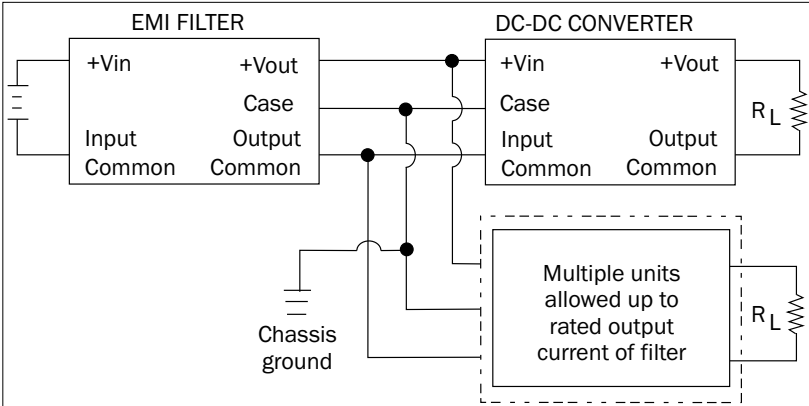

FIGURE 1: SCHEMATIC



The case ground connection between the filter and the converter should be as low an impedance as possible to minimize EMI. Direct contact of baseplate to chassis ground provides the lowest impedance.

FIGURE 2: CONNECTION DIAGRAM

PIN OUT (ALL CASES)	
Pin ¹	Designation
1, 2, 3	Positive Input
4, 5, 6	Input Common
7, 8, 9	Output Common
10, 11, 12	Positive Output
—	Case Ground ²

- Notes
1. All pins must be connected.
 2. The baseplate is the only case ground connection and should directly contact chassis ground.

TABLE 1: PIN OUT

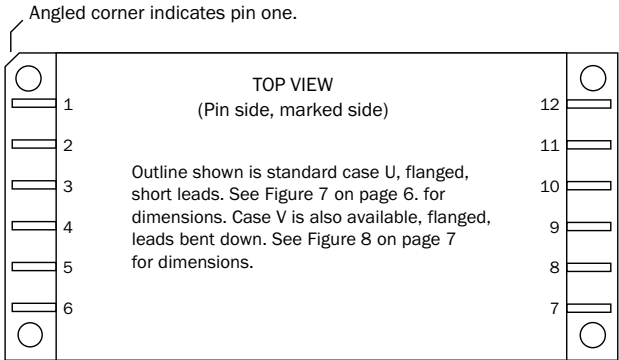

FIGURE 3: PIN OUT

SFME28-461 EMI Input Filters

0 TO 50 VOLT INPUT – 10 AMP

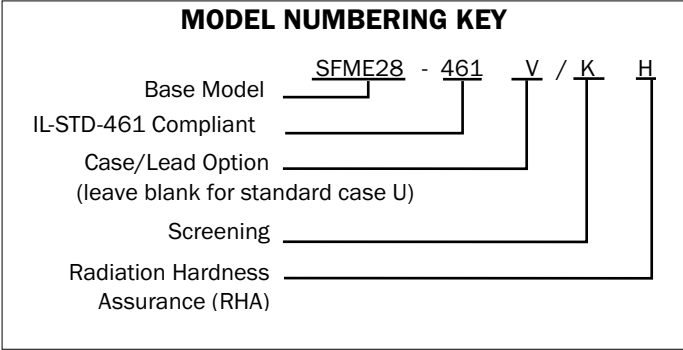

FIGURE 4: MODEL NUMBERING KEY

DLA DRAWINGS	
DLA DRAWING (5915)	VENDOR SIMILAR PART
95004H03HUC	SFME28-461V/HH
95004H03KUC	SFME28-461V/KH
95004H03HXC	SFME28-461/HH
95004H03KXC	SFME28-461/KH

The DLA Drawing numbers shown are for RHA level H, screening level Class K, standard case (X), non-solder dipped pins (C). For other options please refer to the DLA Drawing for the DLA number and the vendor similar number. All DLA Drawing numbers are listed on the DLA Drawing at the end of the document. For exact specifications for a DLA Drawing product, refer to the DLA Drawing. DLA Drawings can be downloaded from <https://landandmaritimeapps.dla.mil/programs/smcr>

TABLE 2: DLA DRAWINGS

MODEL NUMBER OPTIONS ¹				
TO DETERMINE THE MODEL NUMBER ENTER ONE OPTION FROM EACH CATEGORY IN THE FORM BELOW.				
CATEGORY	Base Model and Input Voltage	Case Option ²	Screening ³	RHA ⁴
OPTIONS	SFME28-461	(standard, leave blank) V (leads bent down)	O H K	O H
FILL IN FOR MODEL # ⁵	SFME28-461	_____	/	_____

Notes

- See Figure 4, above, for an example of a model number.
- Case Options: Case U is the standard case (Figure 7 on page 6), leave the case option blank for case U. For case V (Figure 8 on page 7), place a "V" in the case option position.
 - DLA Drawing number 9500403HUC specifies DLA case U which is the vendor case "V" (SFME28-461V/HH). DLA case U, vendor case V, is the long down-leaded option, shown in Figure 8 on page 7.
 - DLA Drawing number 9500403HXC specifies DLA case X which is the vendor standard case and is not included in the vendor model number (SFME28-461/HH). DLA case X and vendor standard case is the short-leaded option shown in Figure 7 on page 6.
- Screening: A screening level of O is a Space Prototype and is only used with RHA O. See Table 6 on page 8 for more information. "H" indicates Class H and "K" indicates Class K of MIL-PRF-38534.
- RHA: Interpoint model numbers use an "O" in the RHA designator position to indicate the "-" (dash) RHA level of MIL-PRF-38534, which is defined as "no RHA." RHA O is only available with Screening level O. See Table 6 on page 8.
- If ordering by model number add a "-Q" to request solder dipped leads (SFME28-461V/HH-Q).

TABLE 3: MODEL NUMBER OPTIONS

SFME28-461 EMI Input Filters

0 TO 50 VOLT INPUT – 10 AMP

TABLE 4: OPERATING CONDITIONS: 28 VIN, UNLESS OTHERWISE SPECIFIED.

PARAMETER	CONDITIONS	SFME28-461			UNITS
		MIN	TYP	MAX	
LEAD SOLDERING TEMPERATURE ¹	10 SECONDS MAX..	–	–	300	°C
STORAGE TEMPERATURE ¹		-65	–	+150	°C
CASE OPERATING TEMPERATURE	FULL POWER	-55	–	+125	°C
	ABSOLUTE ¹	-55	–	+135	
DERATING OUTPUT POWER/CURRENT ¹	LINEARLY	From 100% at 125°C to 0% at 135°C			
ISOLATION ²	@ 500 VDC AT 25°C	100	–	–	Megohms

Notes

1. Guaranteed by characterization test and/or analysis. Not a production test.
2. Tested with all pins, except case pin, tied together. When testing isolation, discharge the pins before and after testing.

TABLE 5: ELECTRICAL CHARACTERISTICS: -55 TO +125°C CASE, 28 VIN, UNLESS OTHERWISE SPECIFIED.

PARAMETER	CONDITIONS	SFME28-461			UNITS
		MIN	TYP	MAX	
INPUT VOLTAGE ¹	CONTINUOUS	0	28	50	V
	TRANSIENT 100 ms ²	-0.5	–	100	V
INPUT CURRENT ¹	STEADY STATE	–	–	10	A
NOISE REJECTION	500 kHz	60	70	–	dB
	1 MHz	60	70	–	
DC RESISTANCE (R _{DC})	T _C = 25°C	–	–	0.076	Ω
CAPACITANCE ³	T _C = 25°C	50,000	–	70,000	pF
OUTPUT VOLTAGE ¹	STEADY STATE	$V_{OUT} = V_{IN} - I_{IN}(R_{DC})$			V
POWER DISSIPATION ¹	T _C = 25°C	–	–	8.75	W

Notes

1. Guaranteed by characterization test and/or analysis. Not a production test.
2. 0.5 ohm source impedance. Transients up to 100 volts will not damage the filter but will be passed through the filter.
3. Tested with all pins tied together except case pin.

SFME28-461 EMI Input Filters

0 TO 50 VOLT INPUT – 10 AMP

TYPICAL PERFORMANCE PLOTS: 25 °C CASE, UNLESS OTHERWISE SPECIFIED.
FOR REFERENCE ONLY, NOT GUARANTEED SPECIFICATIONS.

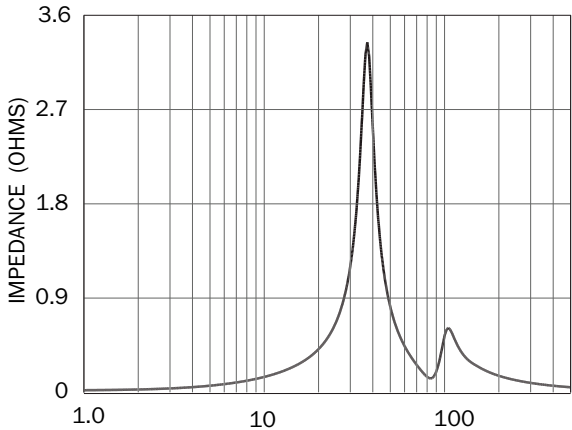

FREQUENCY (kHz)
DC BIAS: 1 AMP
SFME28-461 OUTPUT IMPEDANCE
FIGURE 5

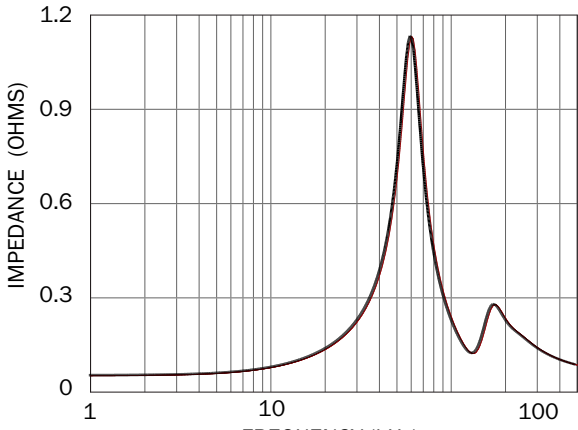

FREQUENCY (kHz)
DC BIAS: 10 AMP
SFME28-461 OUTPUT IMPEDANCE
FIGURE 6

SFME28-461 EMI Input Filters

0 TO 50 VOLT INPUT – 10 AMP

TOP VIEW CASE U
Flanged case, short leads

Case "U" does not require an option in the Case Option position of the model number.

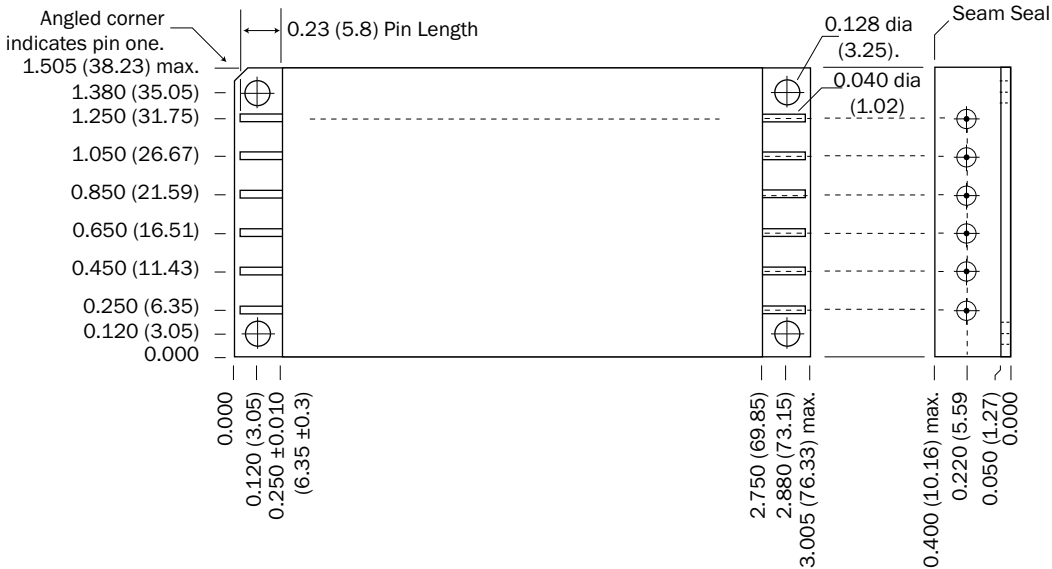

Weight: 86 grams maximum

Case dimensions in inches (mm)
Tolerance ± 0.005 (0.13) for three decimal places
 ± 0.01 (0.3) for two decimal places
unless otherwise specified

CAUTION
Heat from reflow or wave soldering may damage the device. Solder pins individually with heat application not exceeding 300°C for 10 seconds per pin.

Materials
Header Cold Rolled Steel/Nickel/Gold
Cover Kovar/Nickel
Pins #52 alloy/Gold, compression glass seal
Gold plating of 50 - 150 microinches is included in pin diameter
Seal Hole: 0.120 \pm 0.002 (3.05 \pm 0.05)

Please refer to the numerical dimensions for accuracy.

FIGURE 7: CASE U

SFME28-461 EMI Input Filters

0 TO 50 VOLT INPUT – 10 AMP

TOP VIEW CASE V
Flanged case, down leaded

Case "V" requires a "V" in the Case Option position of the model number.

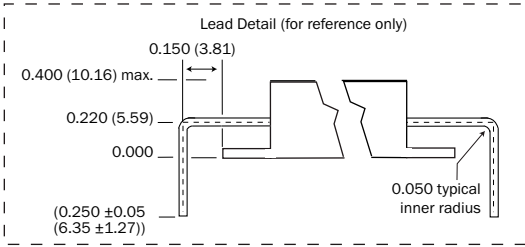
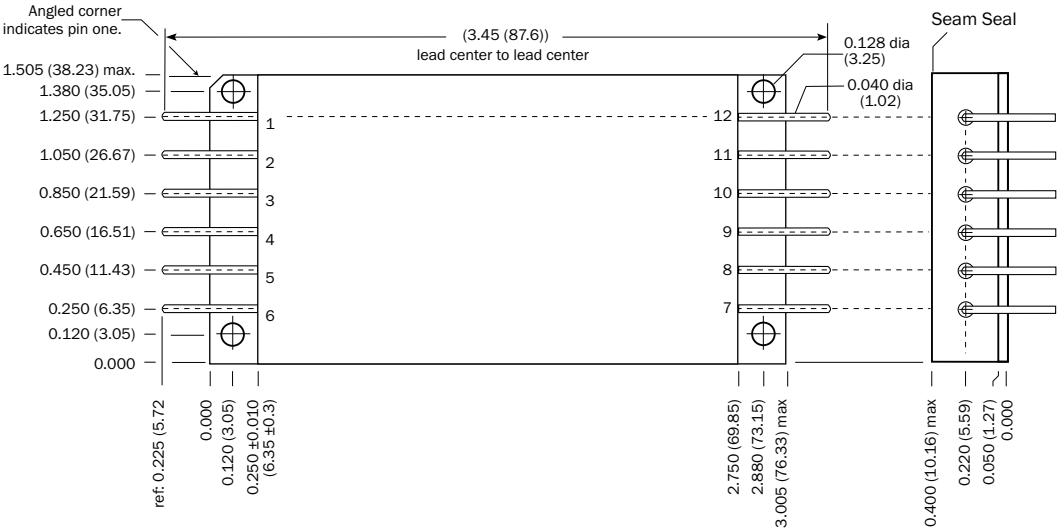

Weight: 86 grams maximum

Case dimensions in inches (mm)
Tolerance ±0.005 (0.13) for three decimal places
±0.01 (0.3) for two decimal places
unless otherwise specified

CAUTION
Heat from reflow or wave soldering may damage the device. Solder pins individually with heat application not exceeding 300 °C for 10 seconds per pin.

Materials
Header Cold Rolled Steel/Nickel/Gold
Cover Kovar/Nickel
Pins OFHC copper/gold, compression glass seal
Gold plating of 50 - 150 microinches
Included in pin diameter
Seal Hole: 0.120 ±0.002 (3.05 ±0.05)

Please refer to the numerical dimensions for accuracy

FIGURE 8: CASE V

SFME28-461 EMI Input Filters

0 TO 50 VOLT INPUT – 10 AMP

ELEMENT EVALUATION TABLES FOR QML PRODUCTS ARE IN “APP-009 QUALITY AND CERTIFICATION”, APPENDIX A, IN COMPLIANCE WITH MIL-PRF-38534 REVISION L.
(LINK [HTTPS://WWW.CRANEAE.COM/QUALITY-ASSURANCE-MODULAR-POWER](https://www.craneae.com/quality-assurance-modular-power))

ENVIRONMENTAL SCREENING SPACE EMI FILTERS PROTOTYPE, CLASS H AND K, RHA ¹ H

TEST PERFORMED	NON-QML ²	QML ^{3, 4}	
	PROTOTYPE ⁵	CLASS H	CLASS K
	/OO ⁶	/HH ⁶	/KH ⁶
Pre-cap Inspection, Method 2017, 2032	■	■	■
Temperature Cycle (10 times) Method 1010, Cond. C, -65 °C to +150 °C, ambient	■	■	■
Constant Acceleration, Method 2001, 3000 g	■	■	■
PIND, Test Method 2020, Cond. A		■ ⁷	■
Pre burn-in test, Group A, Subgroups 1 and 4	■	■	■
Burn-in Method 1015, +125 °C case, typical ⁸			
96 hours	■		
160 hours		■	
2 x 160 hours (includes mid-BI test)			■
Final Electrical Test, MIL-PRF-38534, Group A,			
Subgroups 1 and 4: +25 °C case	■		
Subgroups 1 through 6, -55 °C, +25 °C, +125 °C case		■	■
Hermeticity Test, Method 1014			
Gross Leak, Cond. B ₂ , Kr85			■
Gross Leak, Cond. C ₁ , fluorocarbon	■	■	
Fine Leak, Cond. B ₁ , Kr85			■
Fine Leak, Cond. A ₂ , helium	■	■	
Radiography, Method 2012			■
Post Radiography Electrical Test, +25 °C case			■ ⁷
Final visual inspection			
Method 2009 of MIL-STD-883		■	■
Magnification 1X ⁹	■		
Radiation tolerance ^{1, 10}			
Passive components, radiation tolerant		■	■

Test methods are referenced to MIL-STD-883 as determined by MIL-PRF-38534.

Notes

- DLA has approved the RHA plan for Interpoint power products. Our SMD products with RHA “H” code meet DLA requirements.
- Non-QML products, prototype (OO), may not meet all of the requirements of MIL-PRF-38534.
- All processes are QML qualified and performed by certified operators.
- Class H or K QML products that have no SMD number are marked “CHH, CKH” per MIL-PRF-38534, Table III instead of “QML”.
- “O” in the RHA designator position in Interpoint model numbers indicates DLA RHA “-” defined as no RHA
- Our EMI filters are designed exclusively with passive components providing maximum tolerance for space environment requirements.
- Not required by DLA but performed to assure product quality.
- Burn-in temperature designed to bring the case temperature to +125 °C minimum. Burn-in is a powered test.
- Visual inspection is performed per an internal document. Product may contain cosmetic irregularities such as dents, dings, scratches, etc. that do not affect form, fit or function.
- Interpoint EMI filters are designed exclusively with passive components providing maximum tolerance for space environment requirements. RHA level H is guaranteed to 1000 krad(Si).

TABLE 6: ENVIRONMENTAL SCREENING SPACE EMI FILTERS PROTOTYPE, CLASS H AND K, RHA H