

J4-20001 QUADRATURE HYBRIDS

TECHNICAL FEATURE

FEATURES

- 20 to 40 MHz

PERFORMANCE

Frequency Range.....	20 - 40 MHz
Isolation.....	25 dB min
Insertion Loss	0.5 dB max
VSWR.....	1.2:1 max
Phase Balance	$\pm 3^\circ$ max
Amplitude Balance	± 0.75 dB max
Impedance.....	50 Ohms
Power Handling	3 Watts max
Operating Temperature Range.....	-54 to +85° C

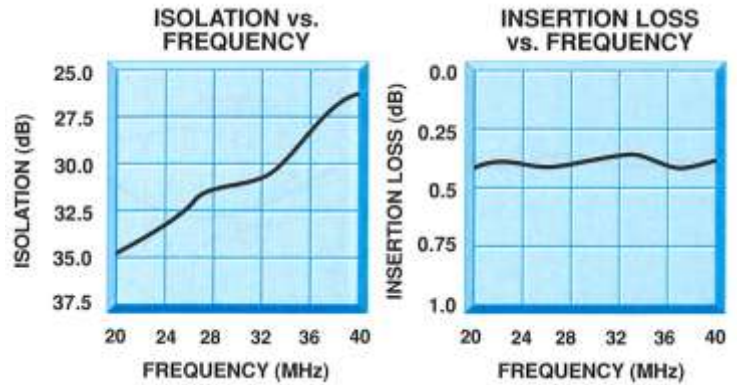

MECHANICAL OUTLINE

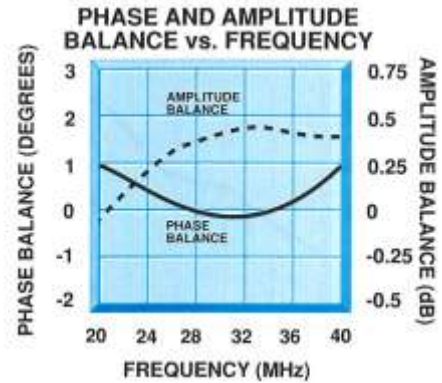
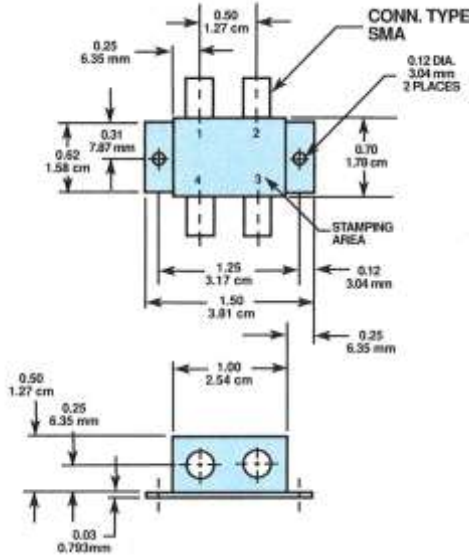

TRUTH TABLE

OUT \ IN	1	2	3	4
1	X	ISOL	0°	-90°
2	ISOL	X	-90°	0°
3	0°	-90°	X	ISOL
4	-90°	0°	ISOL	X